



transform[®]

CABLE RAIL INSTALLATION INSTRUCTIONS

OVERVIEW.....	2
LEVEL.....	3
STAIR.....	13



Transform Cable Rail **MUST** be installed on 4" x 4" wooden posts sleeved with Transform post sleeves to support cable tension!

Need a little help installing your railing?
www.rdirail.com/support/installation-videos.html



CABLE RAIL

Warning: Always wear safety goggles.

Transform Cable Rail MUST be installed on 4" x 4" wooden posts sleeved with Transform post sleeves to support cable tension!

Transform is designed to exceed the most stringent building codes. For most installations everything you need is in the box. When installing spans that are greater than 91" under certain International Building Code conditions, an additional stiffener (see F in component list) may be necessary.

Transform cable fittings are designed to be used with Crossover Product branded cable (73019360 and 73019381). NO OTHER APPLICATIONS OR CABLE CONSTRUCTION ARE RECOMMENDED, SUPPORTED, OR WARRANTED BY RDI/BARRETTE OUTDOOR LIVING.

CARE & MAINTENANCE

Acrylic capstock resins have good resistance to a variety of common cleaners and application environments. It is recommended that you test any cleaner in an inconspicuous area prior to cleaning Transform railing systems. Use proper safety precautions & follow the manufacturers instructions when working with any chemical agents. Properly dispose of chemicals according to your local municipality's regulations for chemical disposal.

Mr. Clean® Magic Erasers® (original style) are the recommended method of cleaning all colors of Transform railing products.

In general, the following chemicals may be safely used with Transform acrylic capped railing system at ambient temperature conditions:

- Formula 409® Cleaner
- Glass Plus® Cleaner
- Liquid Comet® Cleaner
- Mineral Oil
- Mr. Clean® Cleaner
- Soap and water
- Soft Scrub® Cleaner
- Spic and Span® Cleaner

For our steel cable rail, we recommend using our E-Z Clean Cleaner & Protectant. E-Z Clean cleans, lubricates and protects. Simply apply the rust and stain remover and wipe off any rusty areas. Then apply the protectant and wipe off any excess. The wax-based formula reaches deep into metal crevices to displace moisture and dissolve corrosion, and dries to a clean waxy waterproof finish without leaving a sticky residue.

Formula 409® is a registered trademark of The Clorox Company

Glass Plus® is a registered trademark used under authority of Reckitt Benckiser, LLC.

Comet®, Mr. Clean®, and Spic and Span® are registered trademarks of the Procter and Gamble Company

Soft Scrub® is a registered trademark of Henkel Consumer Goods, Inc.



Read all instructions prior to installing product.

Refer to local building codes for installation requirements; failure to install this product in accordance with building codes may affect safety of the product and void product warranty.

Refer to manufacturers safety instructions when operating any tools.

COMPONENT LIST | LEVEL APPLICATION

Depending on the level kit and kit length that you've purchased, your component list will vary. Use this as a guide to identify the individual components.

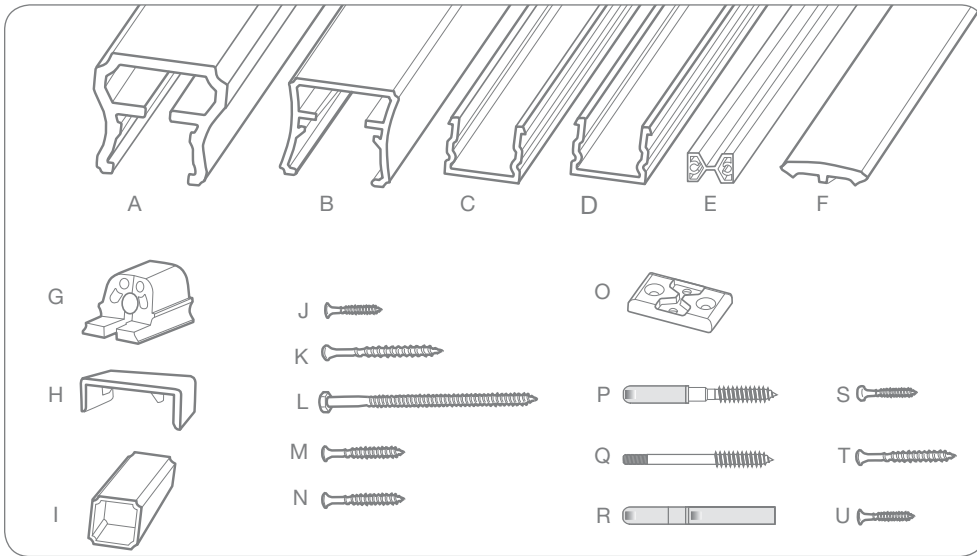

TOOLS NEEDED:

- Safety goggles
- Tape measure
- Pencil
- Level
- Power screwdriver/drill
- Square driver
- Power saw
- Straight edge/ruler/triangle
- Masking tape
- Felco type cable cutter
- 3/8" wrench & Allen wrench

NEEDED FOR INSTALLATION	6' RAIL KIT	8' RAIL KIT
A.) Top Rail (Sold separately – different profiles available)	1	1
B.) Bottom Rail (Optional for installation)	1	1
C.) Bottom Beam (Optional for installation)	1	1
D.) Top Beam	1	1
E.) Mid Baluster Support – Required for spans longer than 42"	1	2
F.) Resalite® Stiffener (shape varies by top rail profile – Sold Separately)	1	1
G.) Mounting Bracket	4	4
H.) Drill Guide	1	1
I.) Bottom Rail Support (Optional if using bottom rail)	1	2
J.) Set Screw (#6 x 3/4")	4	4
K.) Screw (#10 x 2.5")	12	12
L.) Screw (#12 x 5")	1	2
M.) Screw (#10 x 2") – not painted – not needed for this application	6	6
N.) Screw (#10 x 2") – painted to match rail color	4	4
O.) Mid Baluster Support Foot	1	2
P.) Stationary Lag	10 for 36"/12 for 42"	10 for 36"/12 for 42"
Q.) Extended Lag	10 for 36"/12 for 42"	10 for 36"/12 for 42"
R.) Tensioner Fitting	10 for 36"/12 for 42"	10 for 36"/12 for 42"
S.) #10 x 1" Phillips Pan-Head Type F Mid-Baluster Support Screw	4	8
T.) #8 x 1.5" Phillips Flat Head Wood Deck Screw	2	4
U.) #10 x 1" Flat Head Phillips Type F Mid-Baluster Support Screw	2	4

PREPARE POSTS

Transform Cable Rail MUST be installed on 4" x 4" wooden posts sleeved with Transform post sleeves to support cable tension!

1.

Prepare all posts and mounting surfaces before installation. If using a trim ring, be sure to install trim ring prior to attaching your cable and/or fastening bottom beam (optional).

NOTE: Check with your local building code office for design load requirements for guard rails and bottom space requirements. All supporting structures should be built in accordance with applicable building codes.

2.

If using the optional bottom rail, establish the level placement of the bottom rail so that there is no more than a 4" space from the bottom of the rail to the deck (Fig. 1). Mark the post at this dimension to determine your beam placement (Fig. 2 - a). Add 2 1/8" to your bottom space and make a mark on the post at this height to determine where the top of your bottom rail will meet the post. (Fig. 2 - b). Repeat for all posts in your installation.

If not using bottom rail, measure up 1/8" from deck surface on your post to allow for the height of the mid-baluster support foot, and make a mark on the post. Repeat for all posts in your installation.

Determine placement of top rail by measuring up from bottom of post to 33 13/16" for a 36" finished rail height or 39 13/16" for a 42" finished rail height. Repeat for all posts in your installation.

3.

Use the pre-drilled mid-baluster support as a template against the sleeved wooden post to determine your hole placement for both posts in your cable span (Fig. 3). Center the mid-baluster support between the marks for your top rail and bottom rail or mid-baluster support foot to ensure even spacing from your first hole and the top rail and your last hole and the bottom. Mark the mid-baluster support where it lines up with your where your bottom rail or mid-baluster support foot will be, and with the top rail marks. Cut the mid-baluster support. Mark the holes for your cable runs on the post with a pencil, using the mid-baluster support as a template (Fig. 4). Cable system is designed for the cable runs to be 3.1" apart on center.

If using bottom rail there will be 9 cable runs for 36" rail, and 11 for 42" rail. If not using bottom beam, there will be 10 cable runs for 36" rail and 12 cable runs for 42" rail.

A cable span will have stationary lags at one end connecting the cable to the extended lags and tensioners at the other end of the span.

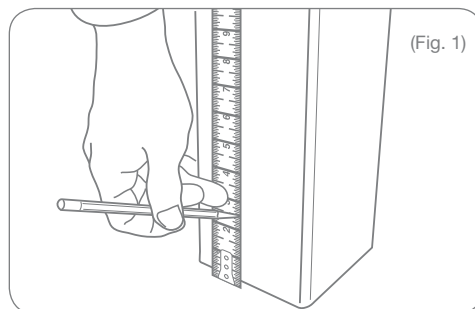

(Fig. 1)

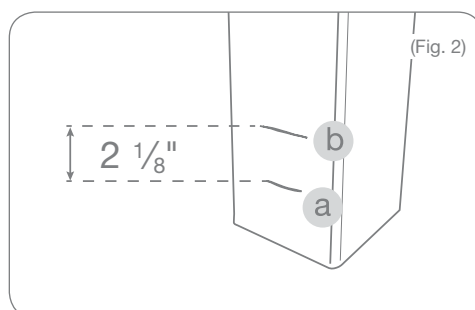

(Fig. 2)

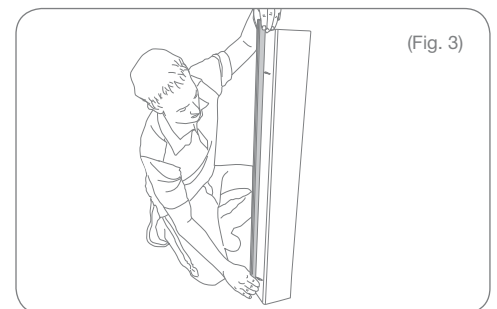

(Fig. 3)

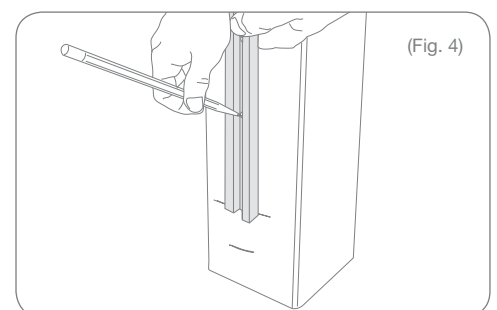

(Fig. 4)

4.

Using a $\frac{7}{32}$ " drill bit for common redwood posts or a $\frac{15}{64}$ " drill bit for Douglas Fir posts, drill at least $1\frac{1}{2}$ " deep into your posts where you've marked for the cable fittings (Fig. 5, top image).

Re-drill through these holes, making sure to drill through the sleeve ONLY using a $\frac{15}{32}$ " drill bit to allow the fitting to anchor into the post (Fig. 5, bottom image).

5.

On the opposite post for your cable span, drill a hole for the extended lag (at the pencil marks made in Step 2) at least $1\frac{1}{2}$ " deep into the wood post. For common redwood posts, use a $\frac{7}{32}$ " drill bit and for common Douglas Fir posts, use a $\frac{15}{64}$ " drill bit (Fig. 6, top image).

Re-drill through these holes, making sure to drill through the sleeve ONLY using a $\frac{5}{16}$ " drill bit to allow the extended lag thread to pass through your post sleeve without damaging it (Fig. 6, bottom image).

6.

For mid posts, the cable can also be run directly through the wooden post so that fittings don't need to be installed at every post (Fig. 7).

To run cable through a mid-post, use the mid-baluster support as a template on both sides of the post to determine hole placement for where the cable will pass through the post. Mark these hole locations with a pencil.

Drill a through-hole at the marks that is $\frac{5}{32}$ " in diameter to pass the cable through.

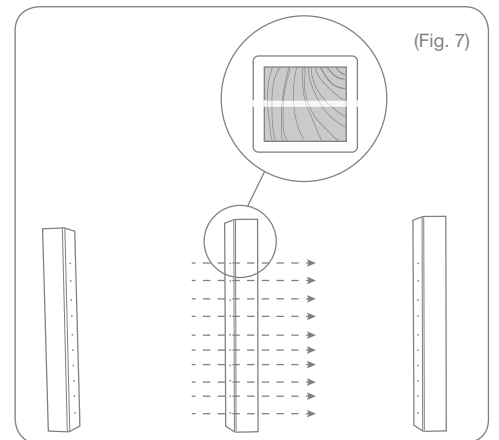
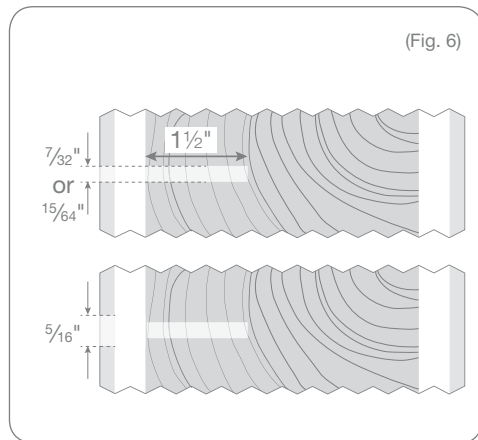
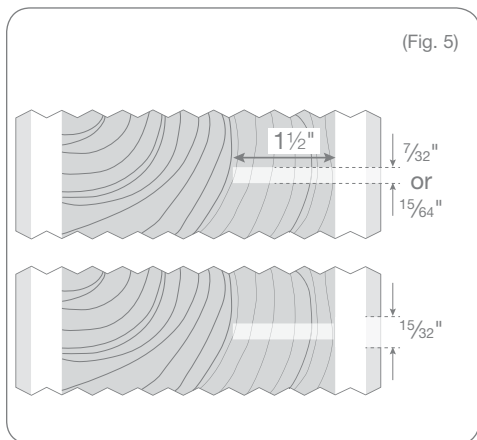

LEVEL RAIL WITH BOTTOM BEAM (OPTIONAL)

7.

Measure the finished opening space between posts (Fig. 8) and cut the bottom rail, bottom beam, and top beam (components B, C, & D) to match this measurement (Fig. 9).

Tip: Use a miter saw with a carbide tip blade of at least 60 teeth.

8.

Insert mounting brackets (component G) in each end of bottom beam if using, (component C) and top beam (component D) (Fig. 10).

Align bracket to end of beam. Measure 1" from back of beam on inside side of rail only and secure set screws (component J) into beam (Fig. 11). This will secure the beam and bracket together. Repeat for top beam.

NOTE: Pre-drilling is not necessary.

9.

Align the bottom beam with the marks determined in Step 2.

Tip: Cut wood blocks to support the bottom beam at the proper height during installation (Fig. 12). Place the blocks under the ends of the rail against the posts.

Secure the lower bracket and beam to the post using 6 mounting screws (component K), 3 per bracket (Fig. 13). Begin with the bottom center screw as shown to avoid misalignment.

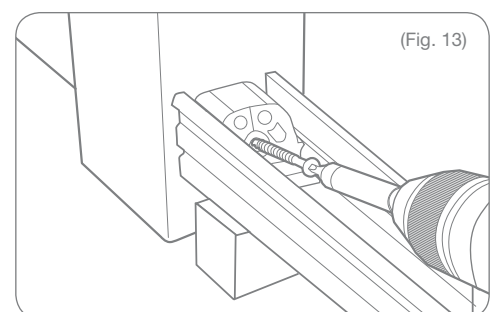
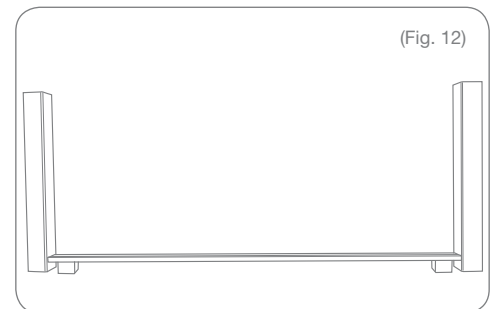
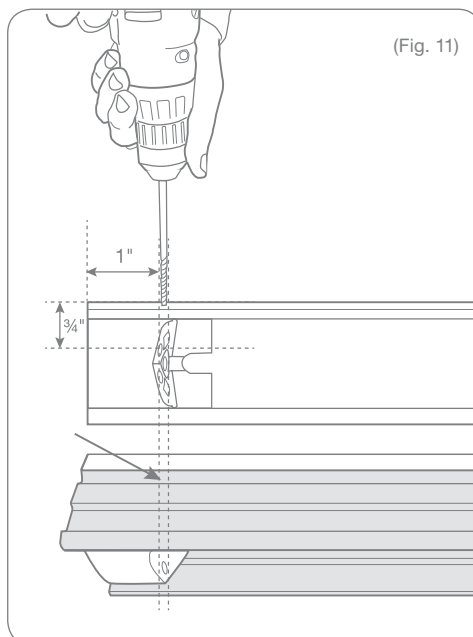
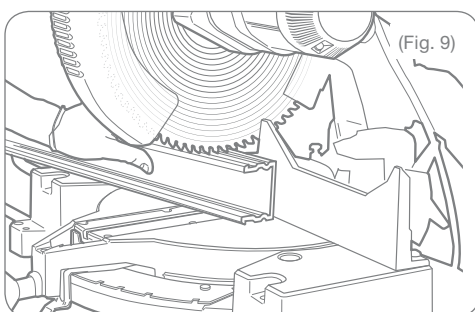
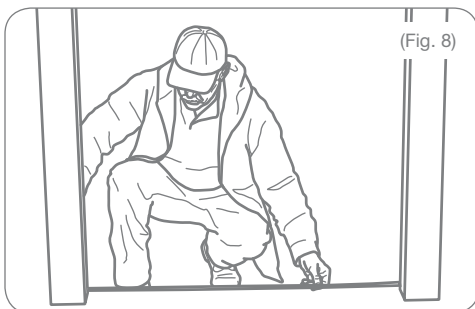
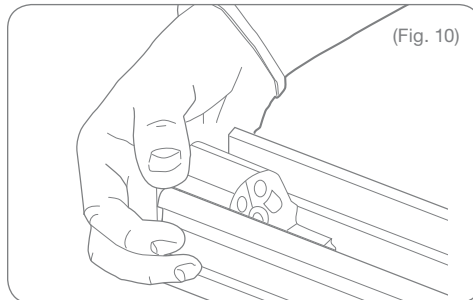

10.

Cut the bottom rail support (component I) to the bottom space determined in Step 2 and place it under the bottom beam at the center point (Fig. 14).

If installing a section larger than 6', evenly space the two rail supports along the span of the bottom rail.

Pre-drill using a $\frac{1}{4}$ " drill bit through the beam (Fig. 15). Screw through the bottom beam (component C) and bottom rail support (component I) into the standing surface with the screws provided (component L). Do not over-tighten.

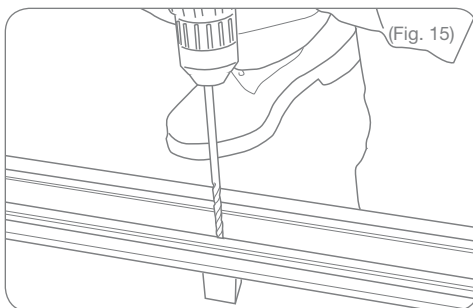
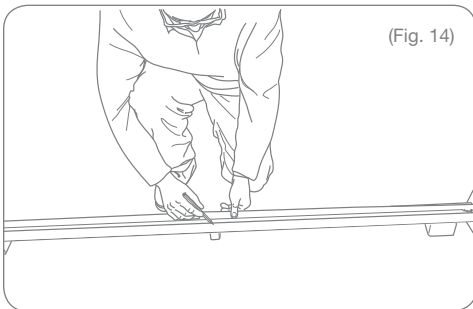

11.

The mid-baluster support is REQUIRED for cable spans over 42"; center the support in your cable span.

WHEN USING OPTIONAL BOTTOM RAIL

Center the mid-baluster support to the top of the bottom rail that was cut in Step 7. Using the mid-baluster support foot as a template (component O), mark the hole location onto your bottom rail. Using a $\frac{3}{16}$ " drill bit, drill through the top of the bottom rail where you marked.

Align your top beam and use the mid-baluster support foot to mark holes on the top beam and pre-drill those as well (Fig. 17).

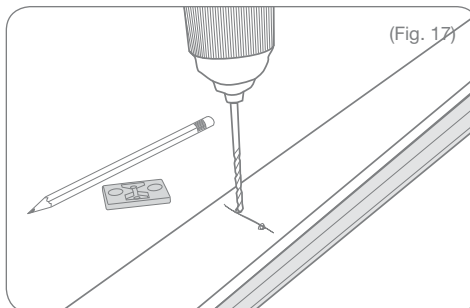
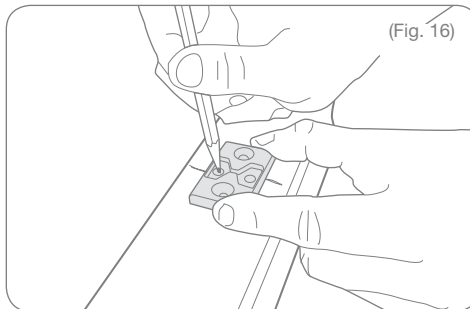

Drive two pan-head screws (component S) up from the underside of the bottom rail to connect the mid-baluster support to the bottom rail. Drive two pan-head screws (S) down through the top beam to connect the mid-baluster support to the top beam (Fig. 18).

Snap the bottom rail (component B) over the bottom beam (component D) (Fig. 19).

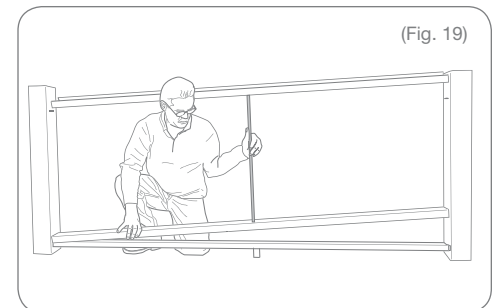
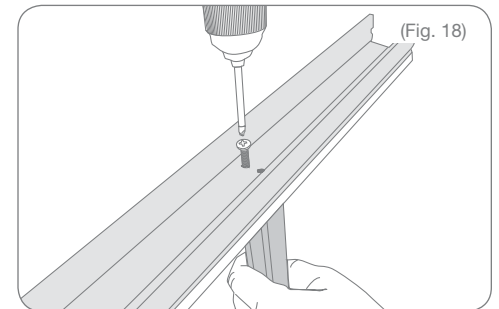

INSTALL TOP RAIL (ALL APPLICATIONS)

12.

The mid-baluster support is REQUIRED for cable spans over 42"; center the support in your cable span.

WITHOUT OPTIONAL BOTTOM RAIL

Align your top beam to where the mid-baluster support will connect, and use the mid-baluster support foot to mark holes on the top beam. Using a $\frac{3}{16}$ " drill bit, pre-drill the holes in your top beam.

Mount the mid-baluster support foot to the bottom of your mid-baluster support using 2 #10 x 1" screws (component U) (Fig. 20). Mount the mid-baluster support to your deck surface using #8 x 1.5" screws (component T) (Fig. 21).

Drive two pan-head screws (component S) down through the top beam to connect the mid-baluster support to the top beam (Fig. 21).

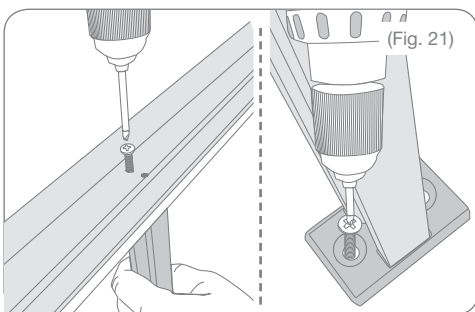
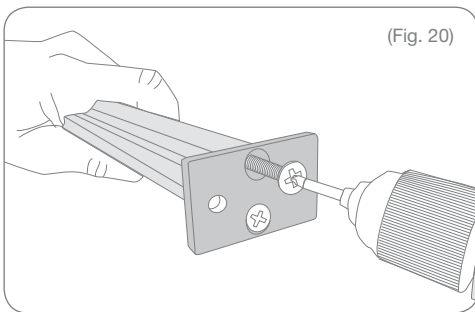

13.

Align the top beam with the marks made in Step 2, ensuring the bottom of the top beam rests squarely on your mid-baluster support.

Secure the upper bracket & beam to the post using 6 mounting screws (component K), 3 per bracket (Fig. 22). Begin with the bottom center screw as shown to avoid misalignment.

14.

Set the drill guide (component H) on top of the bracket, next to rail post. Using a $\frac{1}{8}$ " drill bit (Fig. 23, 24), drill from top of the guide through top bracket and beam. Repeat on other end of rail.

Tip: Ensure drill bit is long enough so that drill chuck does not damage post.

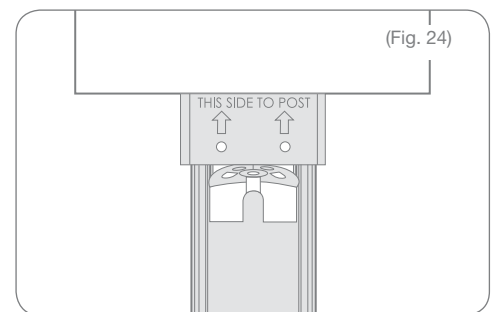
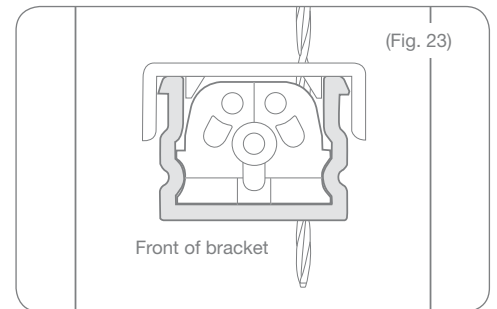
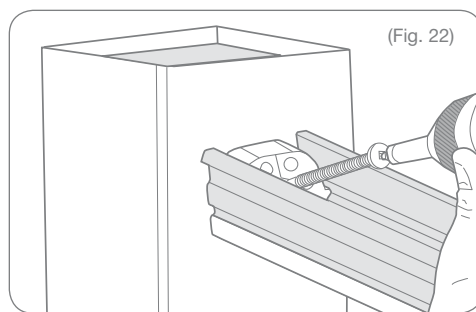

15.

If needed, an additional rail stiffener (component F) can be purchased separately, and installed in top rail (component A) as shown below.

Measure for length (Fig. 25) and cut the top rail (A) with stiffener (F) to fit (Fig. 26).

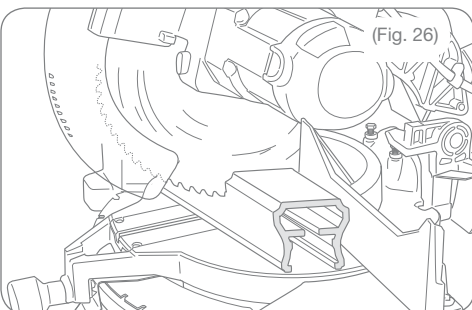
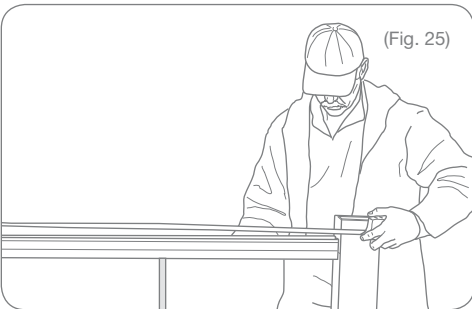
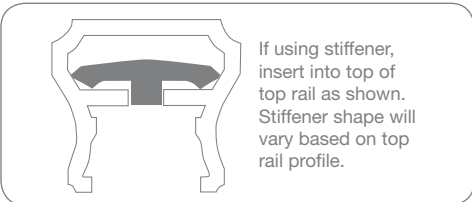
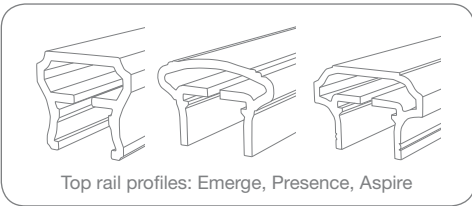

16.

Fasten the top beam to the mid-baluster support by screwing down from the inside channel of the top beam through the holes pre-drilled in Step 11 using #10 x 1" screws (component S) (Fig. 27).

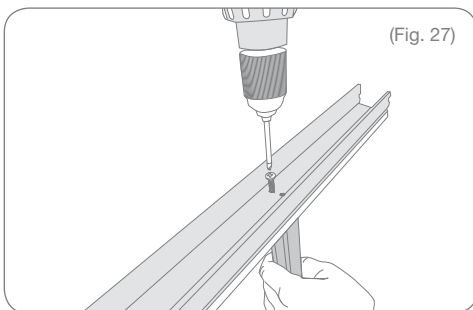

17.

Snap the top rail (component A) onto the top beam (component D). Work from one end of the rail to the other until the full length of the top rail locks into place (Fig. 28).

Using the painted screws (component N) install two of the screws upward from underneath through the pre-drilled location. This will secure the bracket, beam, and top rail together (Fig. 29). Repeat for the other end of the rail.

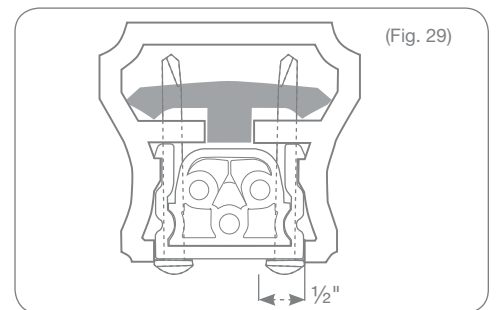
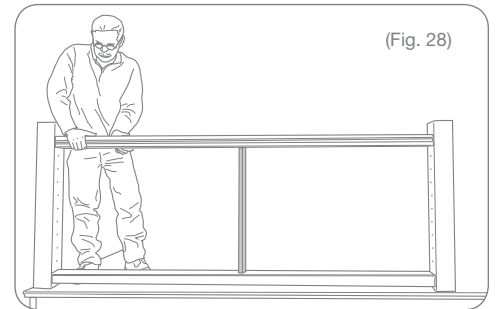

INSTALLING CABLE

18.

Place your stationary lags (component P) into the holes drilled in Step 4 and drive the lag thread into the post using a $\frac{3}{8}$ " open-end wrench on the wrench flats on the fitting. The fitting is secure when the shoulder of the fitting makes contact with the wooden post (Fig. 30). Repeat for all stationary lags.

Place your extended lag (component Q) into the holes drilled in Step 5 and drive the lag threads into the wooden post using a $\frac{3}{16}$ " Allen wrench (Fig. 31). The fitting is secured when the lag threads are fully in the post.

Screw the tensioner (component R) onto the extended lag only so far as to cover the male threads on the extended lag and no more. This slack is needed for when you tighten your cable runs. Repeat for all remaining extended lags.

19.

All cable cut ends must be clean and burr free. We recommend a Felco type cutter that encircles the cable as it cuts it. When inserting a cut end of the cable into fittings, it is important to rotate the cable and/or fitting in the direction that is "with the lay" of the strand to avoid "unraveling" the cable strands.

Insert cut cables into fittings approximately $1 \frac{1}{16}$ " until you feel it rest against a hard stop (Fig. 32), then pull against the fitting to secure the wedges in the fitting (Fig. 33).

NOTE: Full insertion of the cable is CRITICAL to fitting performance under tension! Cable CAN be removed at this point using the cable release key (sold separately, item 73025484).

20.

Once the cable is locked into one end of the fitting, feed the other end through all intermediate posts (if using) and the mid-baluster support (required for cable spans over 42" long) (Fig. 34).

Pull the cable taut alongside the extended lag with tensioner, and mark the cable at the score line indicated on the body of the tensioner as shown in Figure 35. Use your cable cutters to cut the cable at this mark.

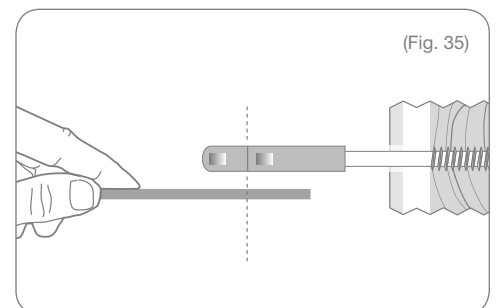
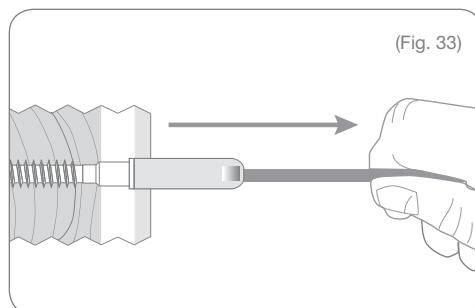
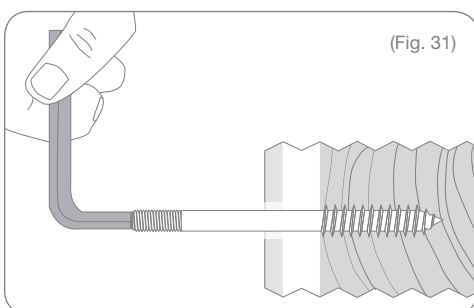
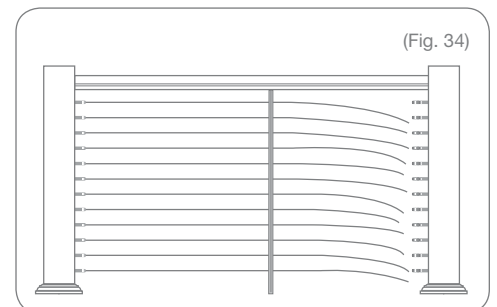
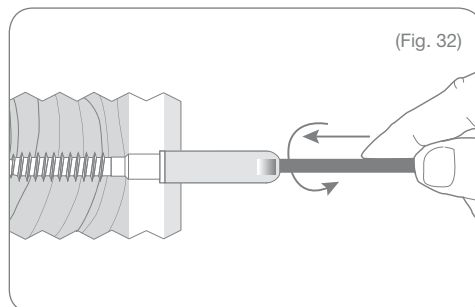
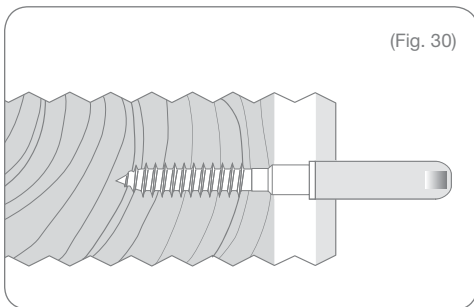

21.

Loosen the tensioner so that approximately 5 or 6 threads are showing and then push the cable into the fitting, rotating the fitting in the direction shown (Fig. 36). Once the cable has bottomed out in the fitting, pull the cable away from the post to help set the locking mechanism to lock the cable into the fitting (Fig. 37).

NOTE: Full insertion of the cable is CRITICAL to fitting performance under tension! Cable CAN be removed at this point using the cable release key (sold separately, item 73025484).

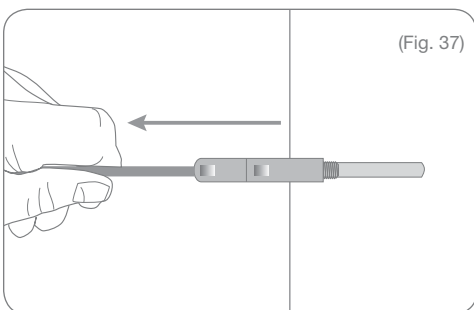
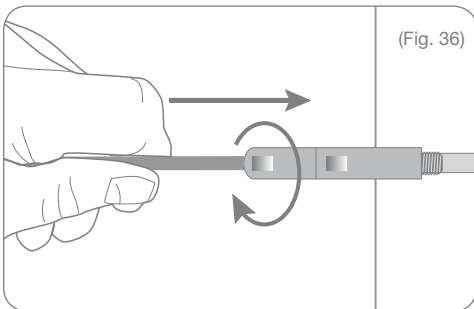

22.

Tension the cable by holding the cable-gripping portion of the fitting stationary (Fig. 38 - a), using a 3/8" wrench as you rotate the female threaded portion of the fitting with a separate 3/8" wrench (Fig. 38 - b).

Tension all the cables to desired amount in sequence, beginning with the bottom cable, then the top, then second up from the bottom, then second down from the top and so forth (Fig. 39). Number of cable runs will be determined by finished rail height and optional use of bottom rail.

NOTE: Cable can NOT be removed once tensioned!

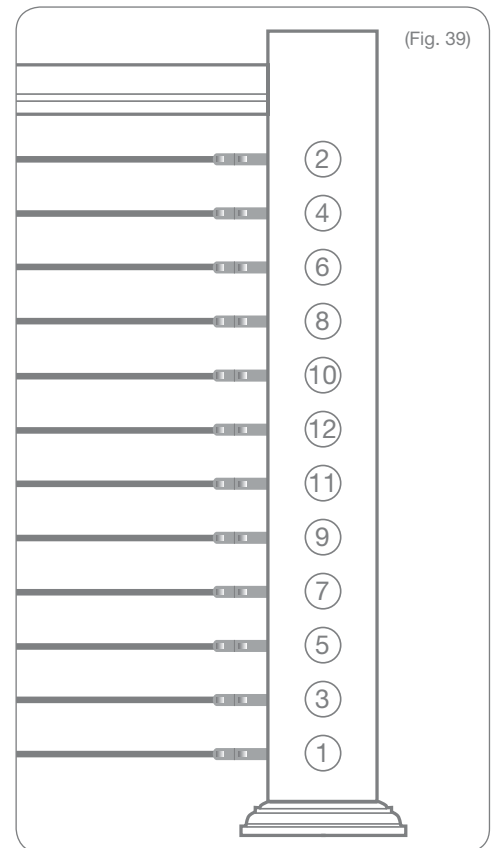
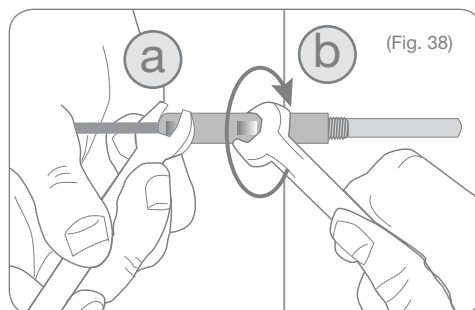

COMPONENT LIST | STAIR APPLICATION

Depending on the kit you've purchased, your component list will vary. Use this as a guide to identify the individual components.

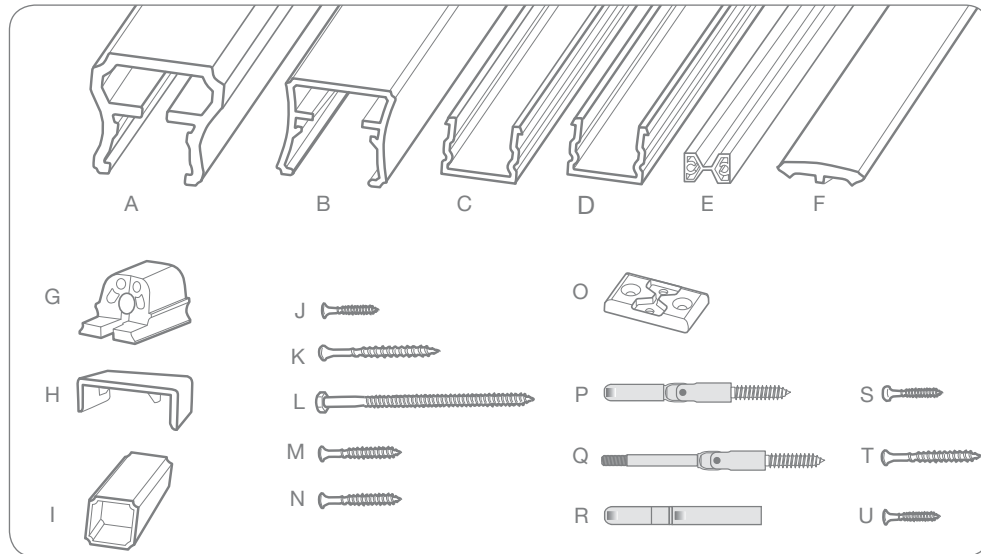

TOOLS NEEDED:

- Safety goggles
- Tape measure
- Pencil
- Level
- Power screwdriver/drill
- Square driver
- Power saw
- Straight edge/ruler/triangle
- Masking tape
- Felco type cable cutter
- 3/8" wrench & Allen wrench

NEEDED FOR INSTALLATION	6' RAIL KIT	8' RAIL KIT
A.) Top Rail (Sold separately – different profiles available)	1	1
B.) Bottom Rail (Optional for installation)	1	1
C.) Bottom Beam (Optional for installation)	1	1
D.) Top Beam	1	1
E.) Mid Baluster Support – Required for spans longer than 42"	1	2
F.) Resalite® Stiffener (shape varies by top rail profile – Sold Separately)	1	1
G.) Mounting Bracket	4	4
H.) Drill Guide	1	1
I.) Bottom Rail Support (Optional if using bottom rail)	1	2
J.) Set Screw (#6 x 3/4")	4	4
K.) Screw (#10 x 2.5")	12	12
L.) Screw (#12 x 5")	1	2
M.) Screw (#10 x 2") – not painted – not needed for this application	6	6
N.) Screw (#10 x 2") – painted to match rail color)	4	4
O.) Mid Baluster Support Foot	1	2
P.) Stair Lag	10 for 36"/12 for 42"	10 for 36"/12 for 42"
Q.) Extended Stair Lag	10 for 36"/12 for 42"	10 for 36"/12 for 42"
R.) Tensioner Fitting	10 for 36"/12 for 42"	10 for 36"/12 for 42"
S.) #10 x 1" Phillips Pan-Head Type F Mid-Baluster Support Screw	4	8
T.) #8 x 1.5" Phillips Flat Head Wood Deck Screw	2	4
U.) #10 x 1" Flat Head Phillips Type F Mid-Baluster Support Screw	2	4



Read all instructions prior to installing product.

Refer to local building codes for installation requirements; failure to install this product in accordance with building codes may affect safety of the product and void product warranty.

Refer to manufacturers safety instructions when operating any tools.

CABLE RAIL | STAIR APPLICATION

Warning: Always wear safety goggles.

Transform Cable Rail MUST be installed on 4" x 4" wooden posts sleeved with Transform post sleeves to support cable tension!

It is **RECOMMENDED** to install Cable Stair Rail with the Transform bottom beam.

If NOT using bottom beam, it is important to note that your installation will vary depending on placement of posts, stair rise and run, stair angle, and bottom space.

WITH BOTTOM RAIL

Continue to page 14 for step-by-step instructions on how to install you cable rail on a stair using the bottom Transform rail.

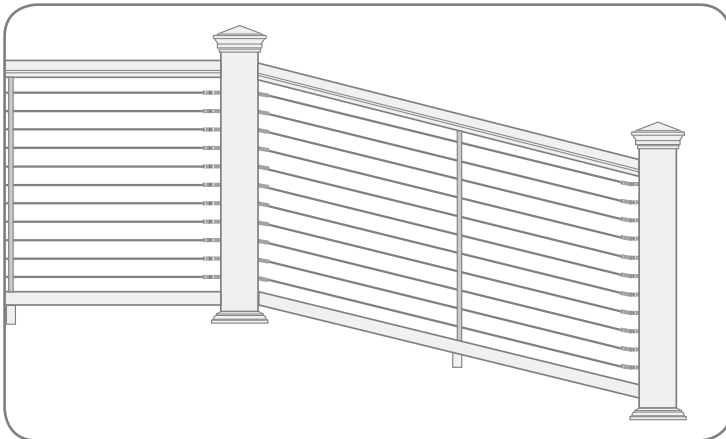

WITH NO BOTTOM RAIL

Skip to page 23 for tips and tricks on how to install your cable rail without the bottom rail.

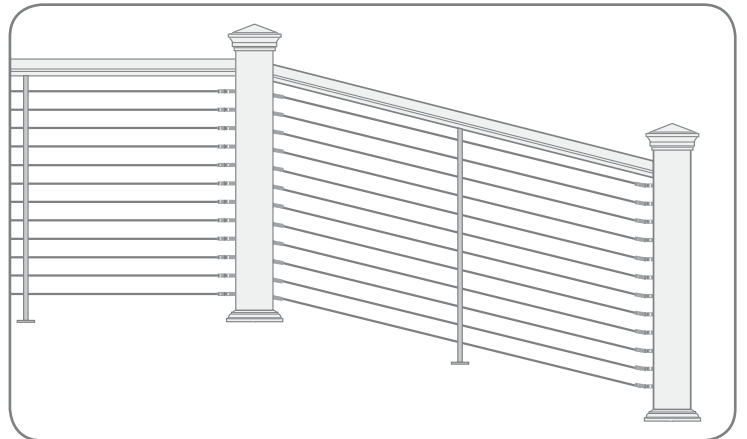

PREPARING POSTS

Transform Cable Rail MUST be installed on 4" x 4" wooden posts sleeved with Transform post sleeves to support cable tension!

1.

Prepare all posts and mounting surfaces before installation. If using a trim ring, be sure to install trim ring prior to attaching your cable and/or fastening bottom beam.

NOTE: Check with your local building code office for design load requirements for guard rails and bottom space requirements. All supporting structures should be built in accordance with applicable building codes.

2.

Temporarily secure a plank on the nose of the stairs along side of the posts onto which you are installing the stair rail (Fig. 1). The thickness of the plank will determine the space between the stairs and the bottom rail.

Mark the post where the top of the plank hits to determine your bottom beam placement (Fig. 2 - a). Repeat for all posts in your installation.

NOTE: Depending on the angle of your stair, code may require you to mount the bottom beam to the tread noses (no plank). Check with your local building office for applicable regulations.

3.

Place the bottom beam (component C) on plank with the flat surface of the bottom beam facing down. Trace the angle of the posts at the inside edge of the posts onto the bottom beam (Fig. 3).

Remove marked bottom beam, and place your bottom rail (component B) on your plank, and clamp in place. Mark the angle of the posts on the bottom rail.

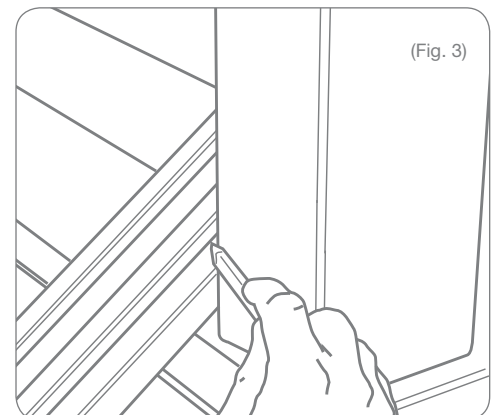
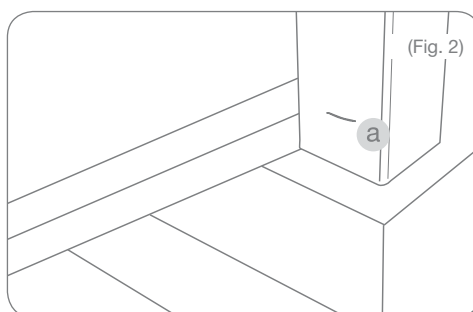
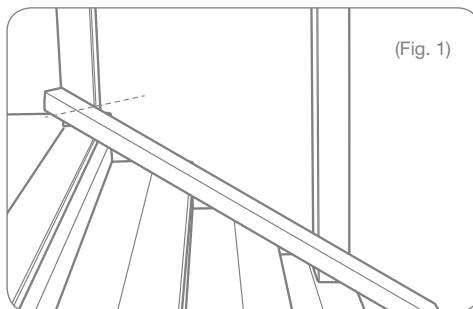

PREPARING POSTS

4.

Determine placement of your top beam (component D). Make a mark at 33 $\frac{3}{8}$ " from deck surface for 36" finished rail height or 39 $\frac{3}{8}$ " from deck surface for 42" finished rail height.

Clamp your top beam in place on your posts so that the bottom of your top beam lines up with your marks. Mark the top beam at the angle where it will need to be cut (Fig. 4).

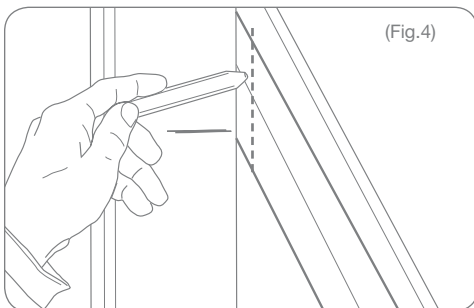

5.

The mid-baluster support (component E) is REQUIRED for cable spans over 42".

Center the mid-baluster support between your top beam and bottom rail at the top stair post to determine even spacing of holes (Fig. 5). For this application, up to 9 holes will be used for cable runs for a 36" finished rail height, and up to 11 will be used for a 42" finished rail height. Mark on your mid-baluster support the angle at which to cut it at both ends (Fig. 6). Cut your mid baluster support at these marks.

NOTE: Both ends of your mid baluster support will need to be cut on the angle to attach to the top beam and bottom rail.

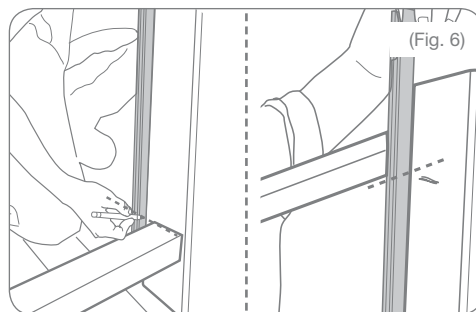

6.

Using your cut mid-baluster support as a template, line it up at the top and bottom of your stair posts and mark your holes using a pencil (Fig. 7).

Determine the placement of your mid-baluster support along your cable span, and mark your top beam and bottom rail where the mid-baluster support will attach (Fig. 8). Un-clamp your bottom rail and top beam.

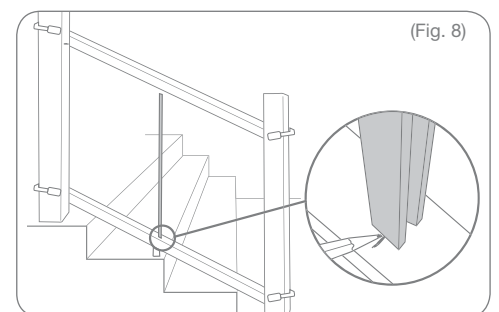

INSTALLING CABLE FITTINGS

7.

Using a $\frac{7}{32}$ " drill bit for common redwood posts or a $\frac{15}{64}$ " drill bit for Douglas Fir posts, pre-drill at least $1\frac{1}{2}$ " deep into your posts where you've marked for the cable fittings (Fig. 9, top image).

Re-drill through these holes, making sure to drill through the sleeve ONLY using a $\frac{17}{32}$ " drill bit to allow the stair lag (component P) to anchor into the post (Fig. 9, bottom image).

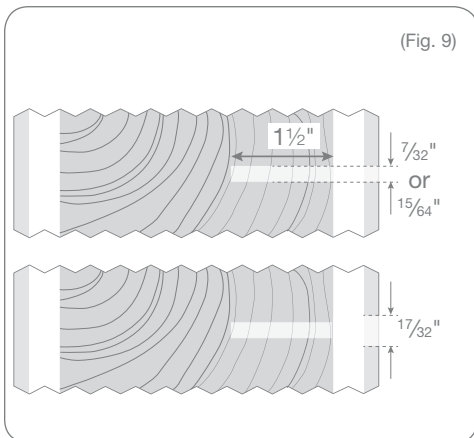

8.

On the opposite post for your cable span, drill a hole for the extended lag (at the pencil marks made from your mid-baluster support) at least $1\frac{1}{2}$ " deep into the wood post. For common redwood posts, use a $\frac{7}{32}$ " drill bit and for common Douglas Fir posts, use a $\frac{15}{64}$ " drill bit (Fig. 10, top image).

Re-drill through these holes, making sure to drill through the sleeve ONLY using a $\frac{17}{32}$ " drill bit to allow the extended stair lag (component Q) to pass through your post sleeve without damaging it (Fig. 10, bottom image).

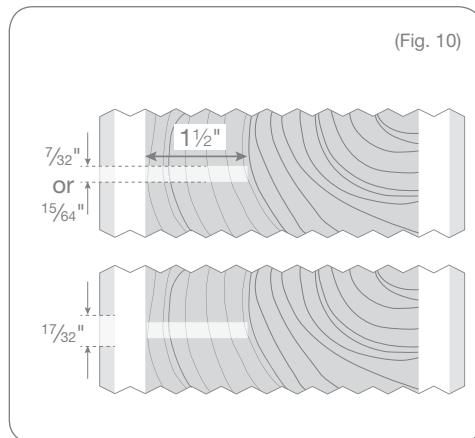

9.

Place your stationary lags (component P) into these holes and drive the lag thread into the post using a $\frac{3}{8}$ " open-end wrench on the wrench flats on the fitting. The fitting is secure when the shoulder of the fitting makes contact with the wooden post (Fig. 11). Repeat for all stationary lags.

Place your extended stair lag (component Q) into the hole and drive the lag threads into the wooden post using a $\frac{3}{16}$ " Allen wrench (Fig. 12). The fitting is secured when the lag threads are fully in the post.

Screw the tensioner (component R) onto the extended lag only so far as to cover the male threads on the extended lag and no more. This slack is needed for when you tighten your cable runs. Repeat for all remaining extended lags.

NOTE: Do not install the bottom fitting on your top stair post to allow for clearance when installing your bottom rail.

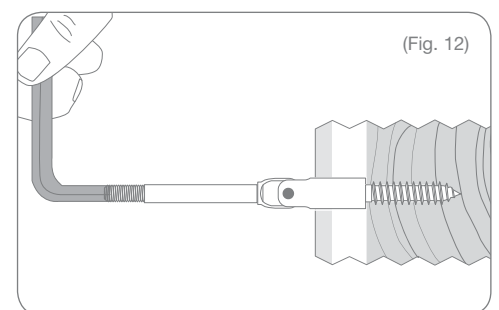
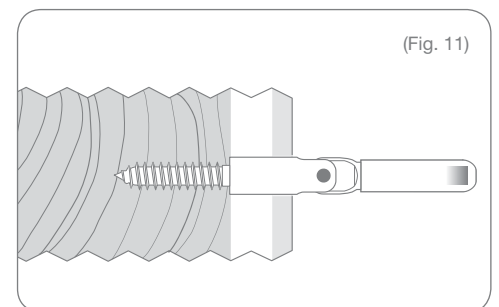

INSTALLING BOTTOM BEAM & BOTTOM RAIL

10.

Wrap enough masking tape around the bracket (Fig. 13) to allow it to fit snugly into the end of the beam. Slide the bracket into the end of the bottom beam. Align brackets with angle marked on beam (Fig. 14) so that when the cut is made, the entire face of the bracket is cut but as little material is removed as possible. With brackets secured into bottom beam, cut through the beam and bracket together on the marked line (Fig. 15) to establish your installation angle. Cut both ends of the bottom beam with the brackets.

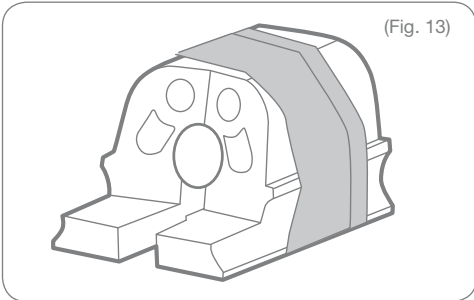

(Fig. 13)

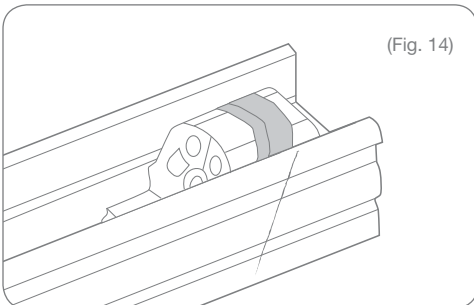

(Fig. 14)

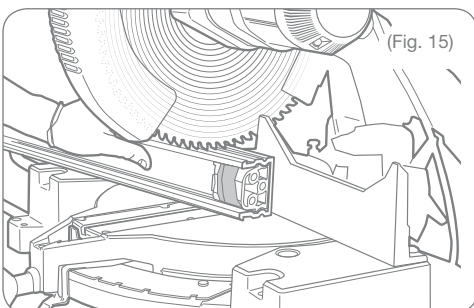

(Fig. 15)

11.

Install a set screw (component J) on the inside of the bottom beam, ensuring set screws connect the beam with the bracket, in the location shown in Figure 16. This should be as close as possible to the inside face of the bracket so that the screw still embeds. Repeat for other end of rail.

Set the bottom beam in position between the two posts, making sure the bottom of the beams are level with the marks made in Step 2 (Fig 17). Pre-drill the post for the center bracket screw using a 1/8" drill bit. Secure the brackets to the post using 3 mounting screws (component K) in each bracket, beginning with the center screw hole (Fig. 18).

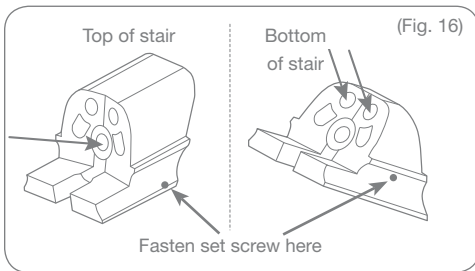

(Fig. 16)

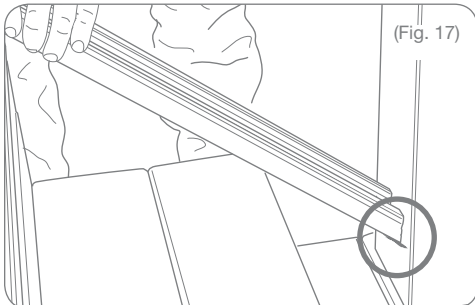

(Fig. 17)

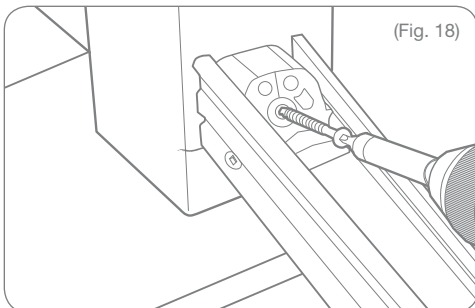

(Fig. 18)

12.

Place the bottom rail support (component I) on the nose of the tread that is nearest to the center of the stair rail section. Trace the bottom of the beam onto the support and cut the support to match the angle. Place the cut support in position under the center of the bottom beam.

Drill through the beam perpendicular to the tread surface using a 1/4" drill bit. It is necessary to drill the beam so the screw will be positioned at the front edge of the bottom rail support to prevent the beam from bowing during installation (Fig. 19). Secure the bottom rail support using the supplied screw (component L).

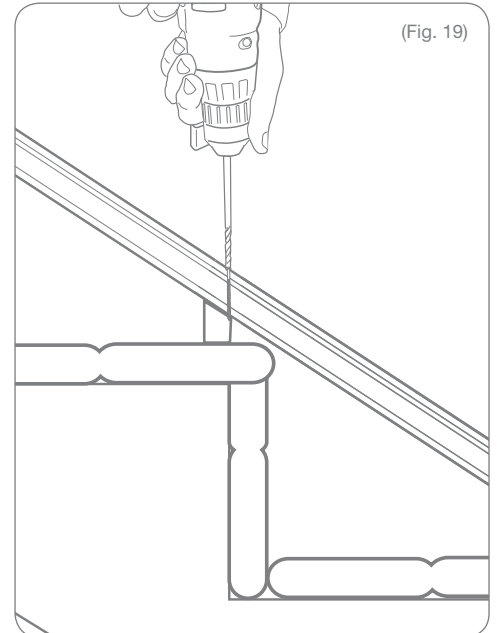

(Fig. 19)

PREPARING BOTTOM RAIL & TOP BEAM

13.

Cut your bottom rail to the length and angle using the marks made in Step 4 (Fig. 20).

Tip: Use a miter saw with a carbide tip blade of at least 60 teeth.

14.

Wrap enough masking tape around the brackets to allow them to fit snugly into the ends of the top beam. Slide the brackets into the ends of the top beam. Align brackets with angle marked on beam (Fig. 21) so that when the cut is made, the entire face of the bracket is cut but as little material is removed as possible. With brackets secured into top beam, cut through the beam and bracket together on the marked line (Fig. 22) to establish your installation angle.

Cut both ends of the top beam with the brackets. Cut your top rail to the same length and angle as your top beam.

15.

Install set screws (component J) on inside of rail only, ensuring set screws connect the beam with the bracket. Fasten in the location shown in Figure 23; this should be as close as possible to the inside face of the bracket so that the screw still embeds, as you did for the bottom beam.

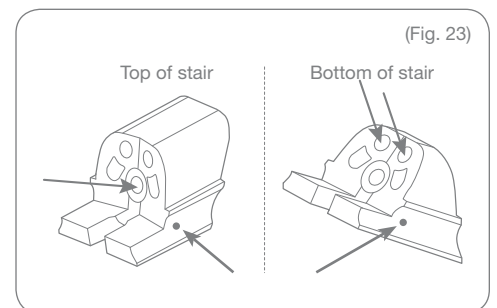
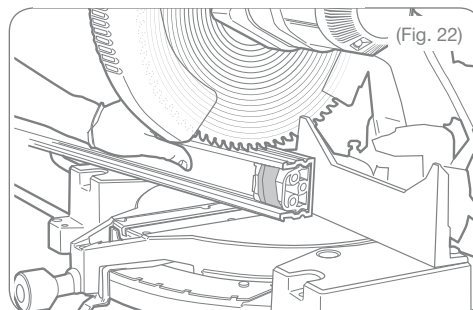
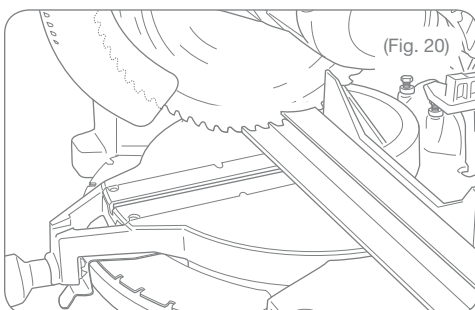
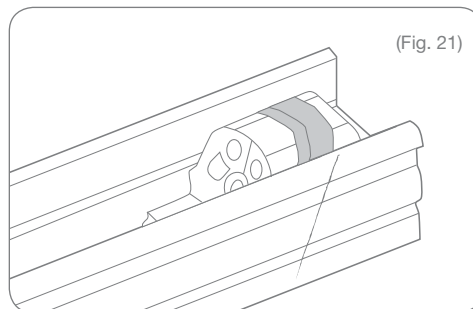

INSTALLING MID BALUSTER SUPPORT

16.

Using the mid-baluster support foot (component O) as a template, center the support foot on your marks (made in Step 6), and mark the holes in your bottom rail and top beam (Fig. 24). These marks are where your mid-baluster support connects to the top beam and bottom rail. Using a $\frac{3}{16}$ " drill bit, pre-drill the holes in your top beam and bottom rail (Fig. 25).

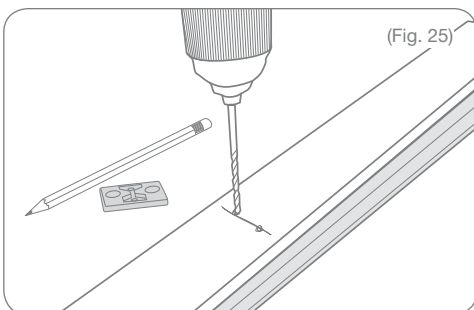
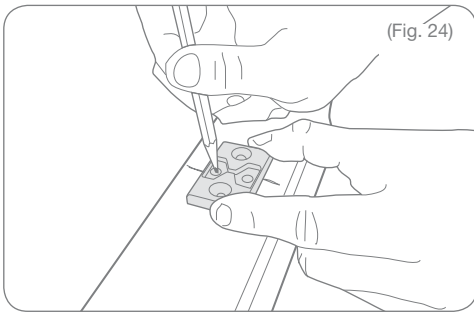

17.

Drive two pan-head screws (component S) up from the underside of the bottom rail to connect the mid-baluster support to the bottom rail. Drive two pan-head screws (S) down through the top beam to connect the mid-baluster support to the top beam (Fig. 26). Be careful not to over-tighten as the pressure from over-tightening could cause the cut end of the mid-baluster support to crack the top beam.

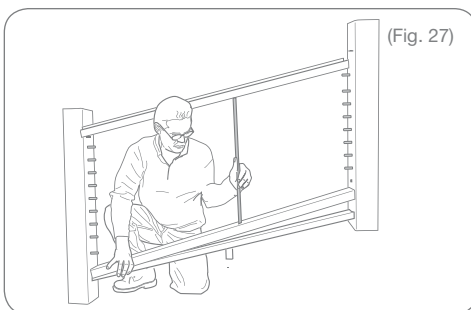
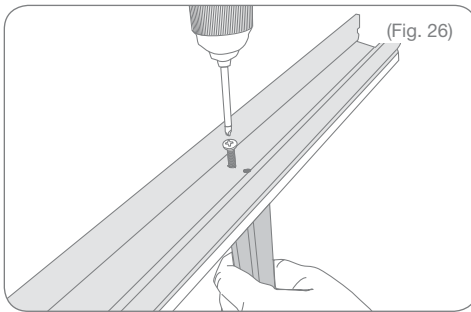

18.

Position the top beam between posts to ensure proper alignment (Fig. 28). Pre-drill the post for the center bracket screw using a $\frac{1}{8}$ " drill bit. Secure the brackets to the post using 3 mounting screws (component K) in each bracket, beginning with the center screw hole (Fig. 29).

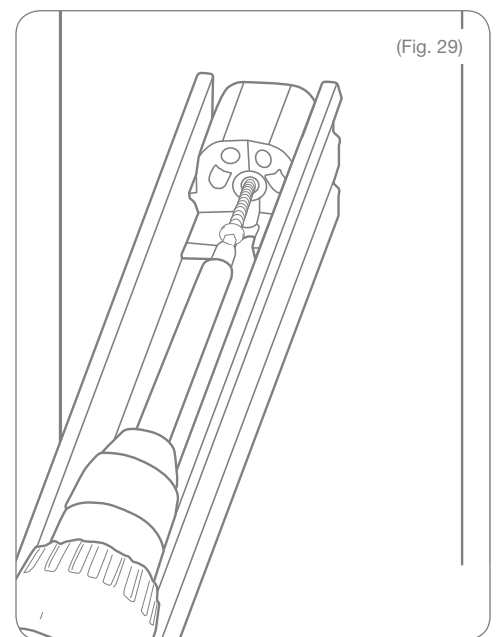
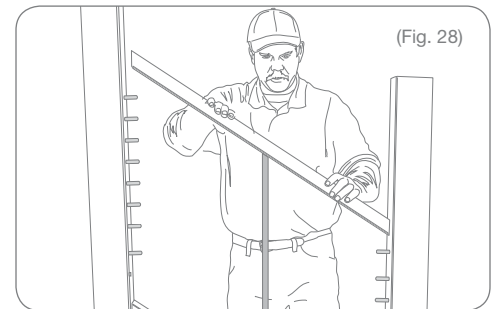

INSTALLING TOP RAIL

19.

Using a 1/8" drill bit, pre-drill downward through the top beam and bracket (Fig. 30).

If needed, an additional rail stiffener (component F) can be purchased separately, and installed in place in top rail (component A) as shown below.

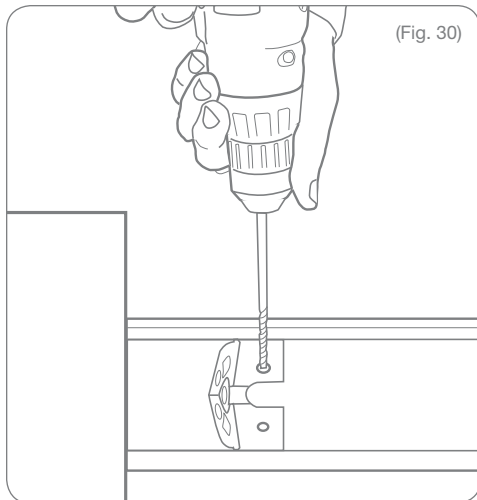
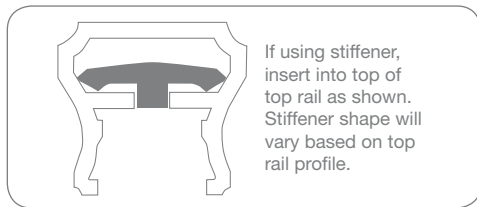

20.

Snap the top rail (component A) onto the top beam (component D) by applying downward pressure. Work from the bottom of the stair to the top end of the rail until the full length of the cover locks into place (Fig. 31 & Fig. 32).

At this time, install the remaining fitting in the pre-drilled hole at the bottom of your top stair post (circled, figure 32.)

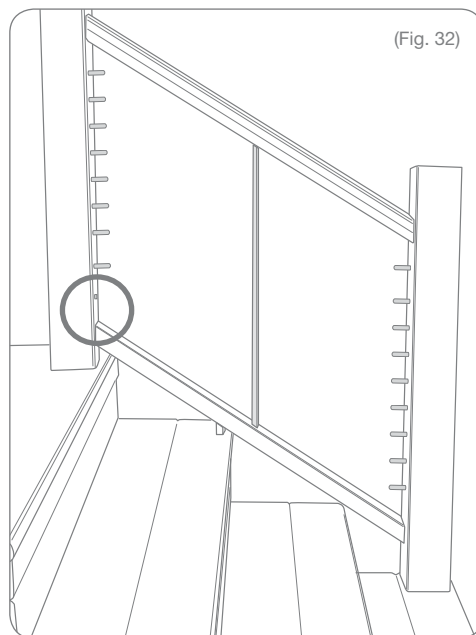
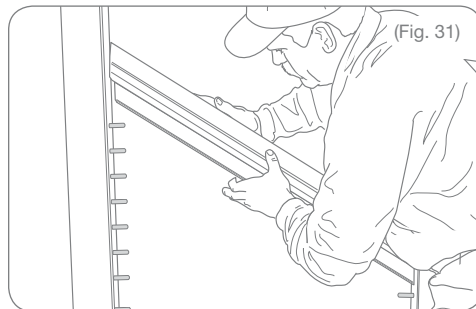

21.

Using the painted screws (component M) install two of the screws upward from underneath each end through the pre-drilled location (Fig. 33). This will secure the bracket, beam, and top rail together (Fig. 34).

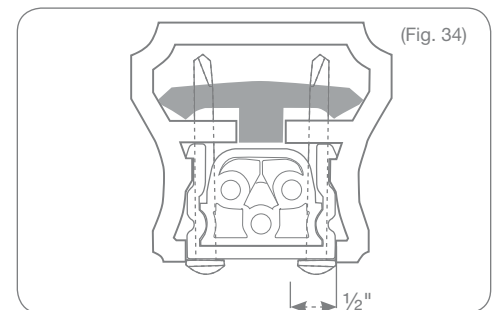
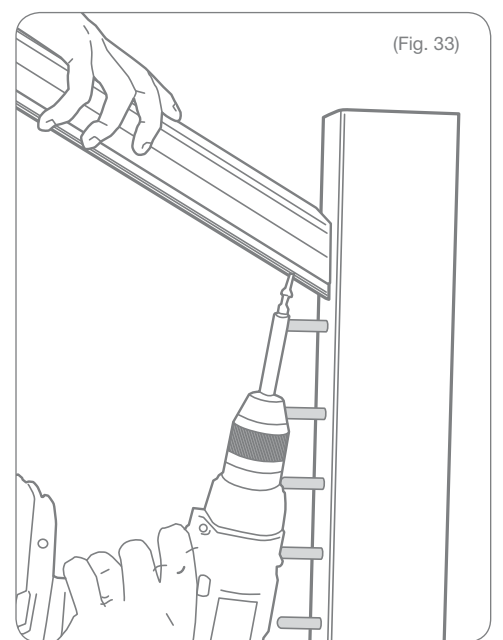

INSTALLING CABLE

22.

All cable cut ends must be clean and burr free. We recommend a Felco type cutter that encircles the cable as it cuts it. When inserting a cut end of the cable into fittings, it is important to rotate the cable and/or fitting in the direction that is “with the lay” of the strand to avoid “unraveling” the cable strands.

Insert cut cables into fittings approximately $1 \frac{1}{16}$ " until you feel it rest against a hard stop (Fig. 35), then pull against the fitting to secure the wedges in the fitting (Fig. 36).

NOTE: Full insertion of the cable is CRITICAL to fitting performance under tension! Cable CAN be removed at this point using the cable release key (sold separately, item 73025484).

23.

Once the cable is locked into one end of the fitting, feed the other end through the mid-baluster support (required for cable spans over 42" long) (Fig. 37).

Pull the cable taut alongside the extended lag with tensioner, and mark the cable at the score line indicated on the body of the tensioner as shown in Figure 38. Use your cable cutters to cut the cable at this mark.

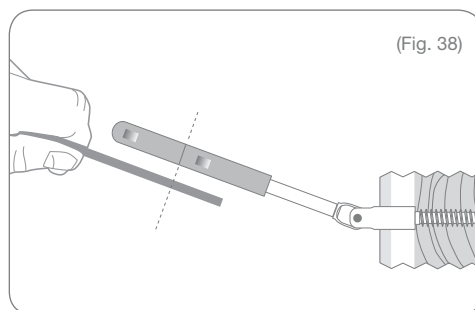
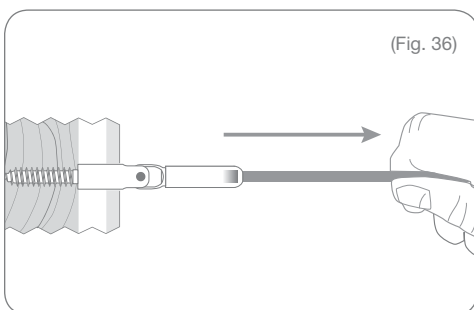
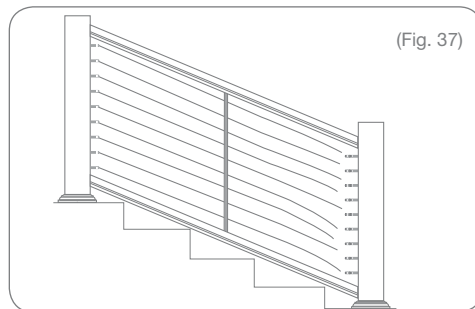
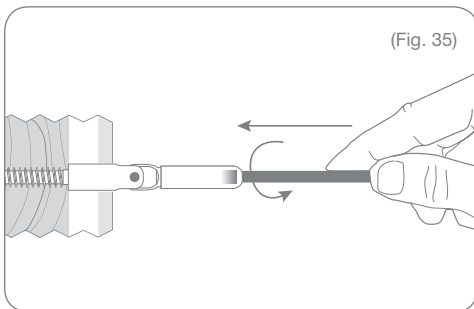

INSTALLING CABLE

24.

Loosen the tensioner so that approximately 5 or 6 threads are showing and then push the cable into the fitting, twisting the fitting in the direction shown in figure 40. Once the cable has bottomed out in the fitting, pull the cable away from the post to help set the locking mechanism to lock the cable into the fitting (Fig. 41).

NOTE: Full insertion of the cable is CRITICAL to fitting performance under tension! Cable CAN be removed at this point using the cable release key (sold separately, item 73025484).

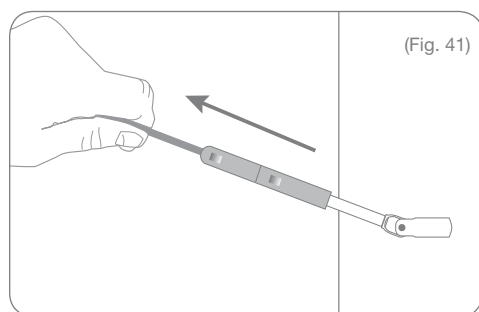
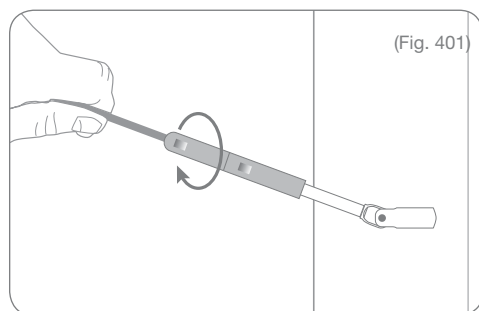

25.

Tension the cable by holding the cable-gripping portion of the fitting stationary (Fig. 42 – a), using a $\frac{3}{8}$ " wrench as you rotate the female threaded portion of the fitting with a separate $\frac{3}{8}$ " wrench (Fig. 42 – b).

Tension all the cables to desired amount in sequence, beginning with the bottom cable, then the top, then second up from the bottom, then second down from the top and so forth (Fig. 43). Number of cable runs will be determined by finished rail height and optional use of bottom rail.

NOTE: Cable can NOT be removed once tensioned!

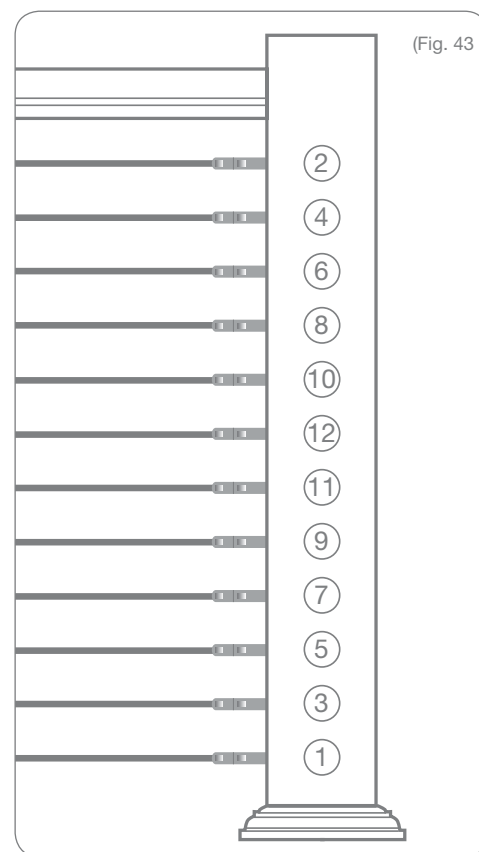
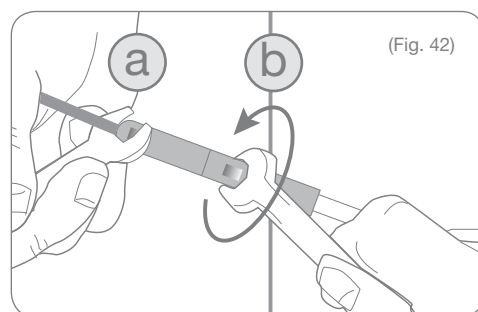

CABLE RAIL | STAIR APPLICATION

Warning: Always wear safety goggles.

Transform Cable Rail MUST be installed on 4" x 4" wooden posts sleeved with Transform post sleeves to support cable tension!

It is **RECOMMENDED** to install Cable Stair Rail with the Transform bottom beam.

If NOT using bottom beam, it is important to note that your installation will vary depending on placement of posts, stair rise and run, stair angle, and bottom space.

WITH NO BOTTOM RAIL

If not using bottom rail, follow these general guidelines for installing cable rail without bottom rail. For 36" finished height, 10 fittings will be used per post, for 42" finished height, 12 fittings will be used. Your installation may vary based on stair angle and post placement.

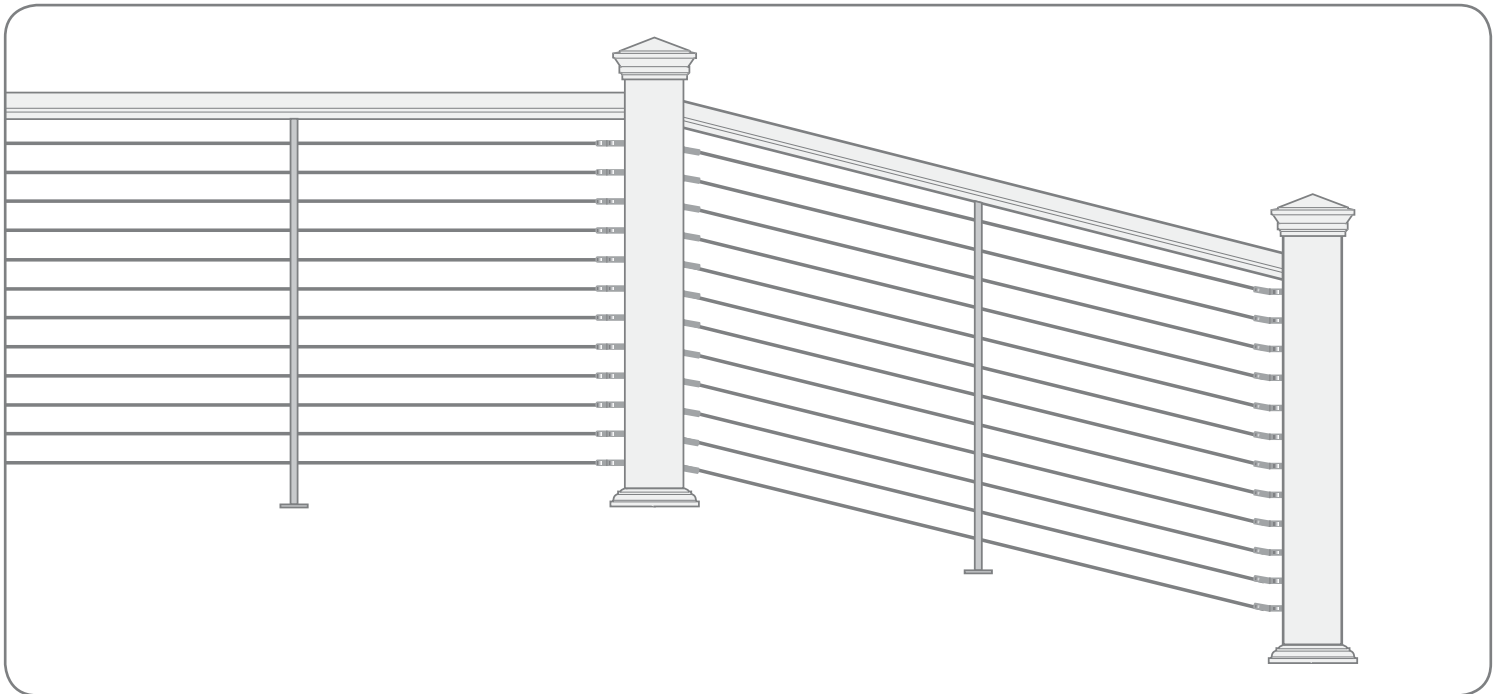

INSTALLING WITH NO BOTTOM RAIL

If not using bottom rail, follow these general guidelines for installing cable rail without bottom rail. For 36" finished height, 10 fittings will be used per post, for 42" finished height, 12 fittings will be used. Your installation may vary based on stair angle and post placement.

1.

Prepare all posts and mounting surfaces before installation. If using a trim ring, be sure to install trim ring prior to attaching your cable and/or fastening bottom beam.

Mark up from deck surface $\frac{1}{8}$ " on your post to account for the mid-baluster support foot (Fig. 1).

NOTE: Check with your local building code office for design load requirements for guard rails and bottom space requirements. All supporting structures should be built in accordance with applicable building codes

2.

Determine placement of your top beam (component D). Make a mark at $33 \frac{3}{8}$ " from deck surface for 36" finished rail height or $39 \frac{3}{8}$ " from deck surface for 42" finished rail height on both your top and bottom stair posts.

Clamp your top beam in place on your posts so that the bottom of your top beam lines up with your marks. Mark the top beam at the angle where it will need to be cut (Fig. 2).

3.

The mid-baluster support is **REQUIRED** for cable spans over 42". If the distance between your top and bottom stair posts is LESS than 42", this mid-baluster support does not need to be installed, but should still be used as a template to determine hole placement.

Your installation may vary depending on number of stairs and stair angle.

Using the marks made in steps 1 and 2, align your mid-baluster support (component E) on your post to determine even spacing of holes. For this application, up to 10 holes will be used for cable runs for a 36" finished rail height, and up to 12 will be used for a 42" finished rail height. Mark on your mid-baluster support the height and angle (Fig. 3 a and b) at which to cut it once you've centered it on the post. Cut your mid baluster support.

NOTE: Only the top end of your mid baluster support will be cut on an angle; the bottom will attach to the mid-baluster support foot and should be cut flat (if needed).

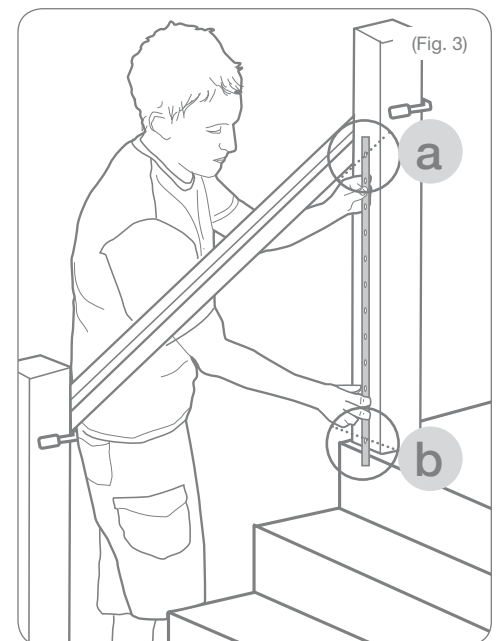
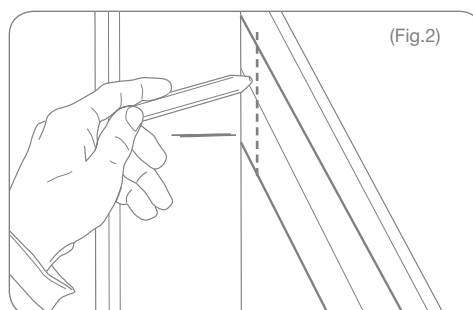
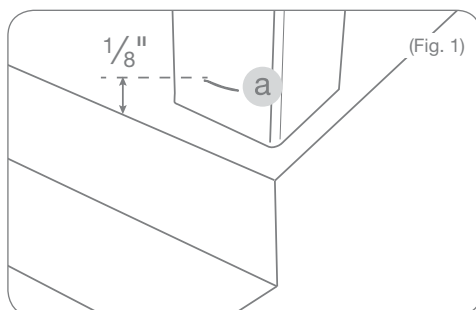

MID BALUSTER SUPPORT (NO BOTTOM RAIL)

4.

Take your mid-baluster support, cut to length, and place in the middle of your cable span. Move the support along the tread of the step so that the top of it meets your top beam (Fig. 4). This placement will vary based on stair angle.

5.

Make a mark on your top beam where the mid-baluster support is centered (Fig. 5). Un-clamp your top beam. Using the mid-baluster support foot (component O) as a template, mark the holes in your top beam where it will attach, and using a $\frac{3}{16}$ " drill bit, pre-drill the holes in your top beam (Fig. 6 and Fig. 7).

6.

Using your cut mid-baluster support as a template, line it up at the top and bottom of your stair posts and mark your holes using a pencil (Fig. 8).

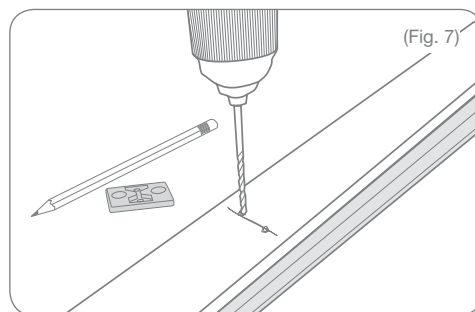
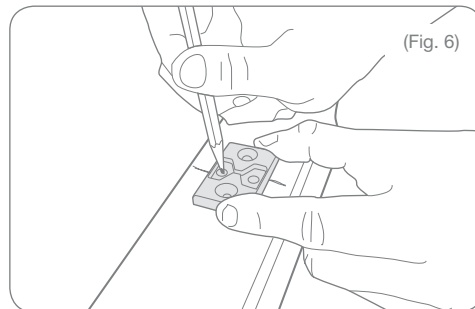
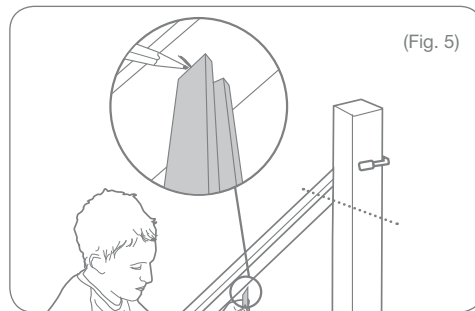
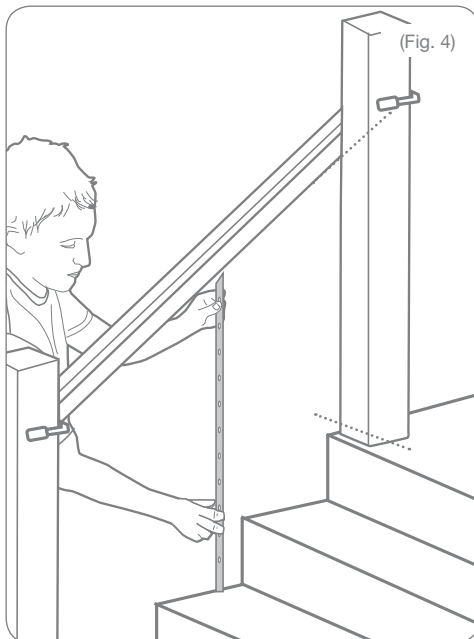

INSTALLING CABLE FITTINGS

7.

Using a $\frac{7}{32}$ " drill bit for common redwood posts or a $\frac{15}{64}$ " drill bit for Douglas Fir posts, pre-drill at least $1\frac{1}{2}$ " deep into your posts where you've marked for the cable fittings (Fig. 9, top image).

Re-drill through these holes, making sure to drill through the sleeve ONLY using a $\frac{17}{32}$ " drill bit to allow the stair lag (component P) to anchor into the post (Fig. 9, bottom image).

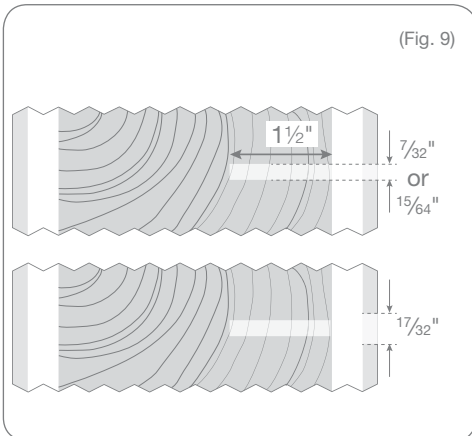

8.

On the opposite post for your cable span, drill a hole for the extended lag (at the pencil marks made from your mid-baluster support) at least $1\frac{1}{2}$ " deep into the wood post. For common redwood posts, use a $\frac{7}{32}$ " drill bit and for common Douglas Fir posts, use a $\frac{15}{64}$ " drill bit (Fig. 10, top image).

Re-drill through these holes, making sure to drill through the sleeve ONLY using a $\frac{17}{32}$ " drill bit to allow the extended stair lag (component Q) to pass through your post sleeve without damaging it (Fig. 10, bottom image).

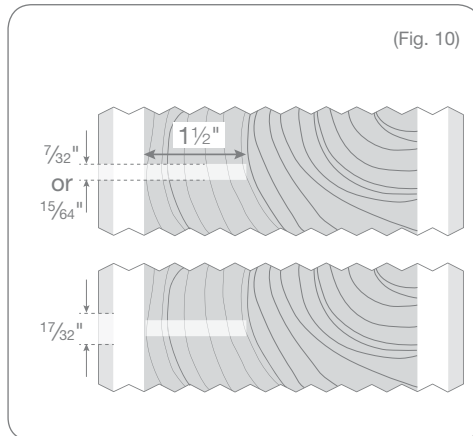

9.

Place your stationary lags (component P) into these holes and drive the lag thread into the post using a $\frac{3}{8}$ " open-end wrench on the wrench flats on the fitting. The fitting is secure when the shoulder of the fitting makes contact with the wooden post (Fig. 11). Repeat for all stationary lags.

Place your extended stair lag (component Q) into the hole and drive the lag threads into the wooden post using a $\frac{3}{16}$ " Allen wrench (Fig. 12). The fitting is secured when the lag threads are fully in the post.

Screw the tensioner (component R) onto the extended lag only so far as to cover the male threads on the extended lag and no more. This slack is needed for when you tighten your cable runs. Repeat for all remaining extended lags.

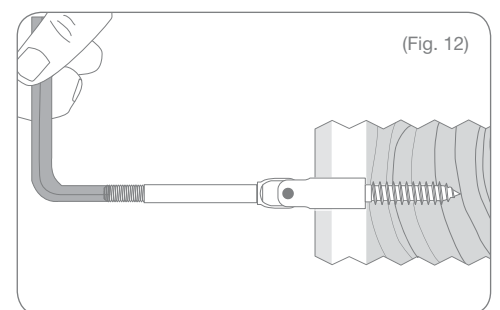
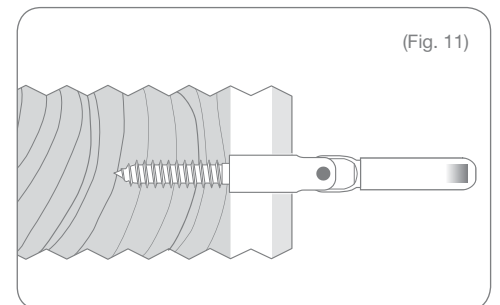

MID BALUSTER SUPPORT (NO BOTTOM RAIL)

10.

Wrap enough masking tape around the brackets to allow them to fit snugly into the ends of the beam. Slide the brackets into the ends of the top beam. Align brackets with angle marked on beam (Fig. 13) so that when the cut is made, the entire face of the bracket is cut but as little material is removed as possible. With brackets secured into top beam, cut through the beam and bracket together on the marked line made in Step 2 (Fig. 14) to establish your installation angle.

Cut both ends of the top beam with the brackets. Cut your top rail (component A) to the same length and angle as your top beam.

11.

Install set screws (component J) on inside of rail only, ensuring set screws connect the beam with the bracket. Fasten in the location shown in figure 15; this should be as close as possible to the inside face of the bracket so that the screw still embeds, as you did for the bottom beam.

12.

Mount the mid-baluster support foot to the bottom of your mid-baluster support using 2 #10 x 1" screws (component U) (Fig. 16). Drive two pan-head screws (component S) down through the top beam to connect the mid-baluster support to the top beam (Fig. 17).

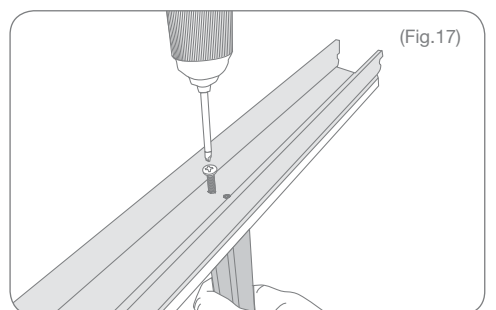
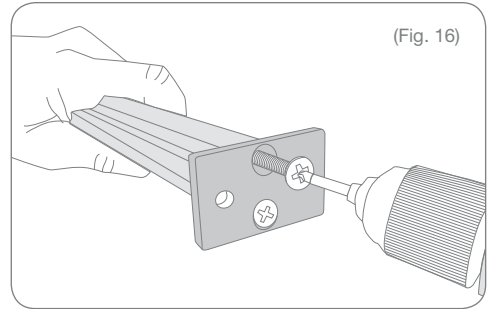
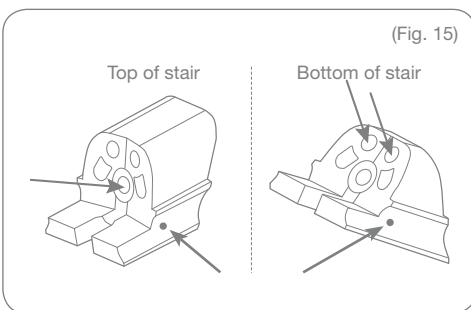
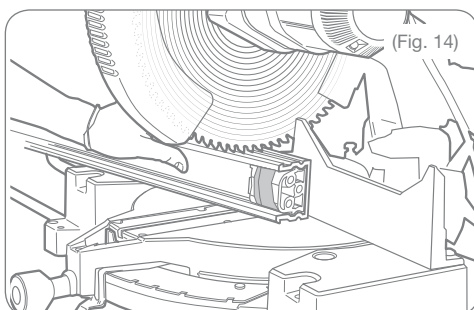
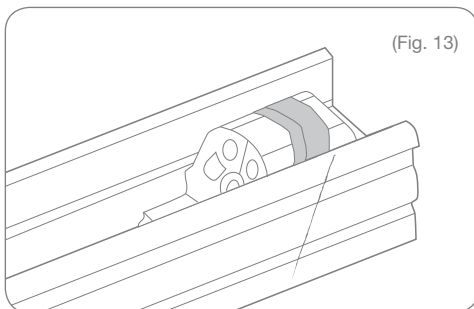

13.

Position the top beam (with attached mid-baluster support) between posts to ensure proper alignment (Fig. 18). Pre-drill the post for the center bracket screw using a $\frac{1}{8}$ " drill bit. Secure the brackets to the post using 3 mounting screws (component K) in each bracket, beginning with the center screw hole (Fig. 19).

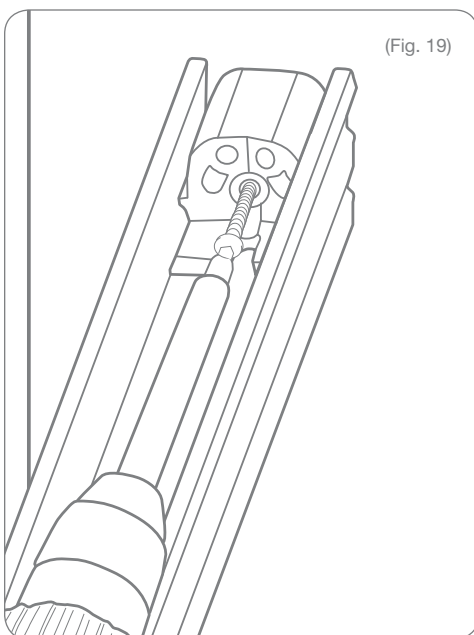

14.

Secure the mid-baluster support to your deck surface using #8 x 1.5" screws (component T) (Fig. 20).

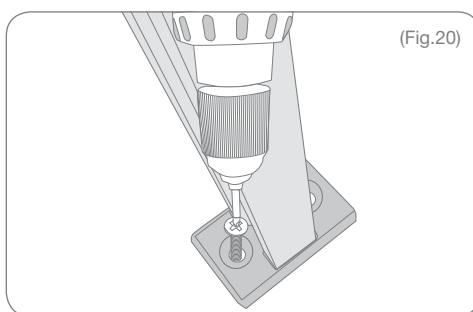

INSTALLING TOP RAIL

15.

Using a 1/8" drill bit, pre-drill downward through the top beam and bracket (Fig. 21).

If needed, an additional rail stiffener (component F) can be purchased separately, and installed in place in top rail (component A) as shown below.

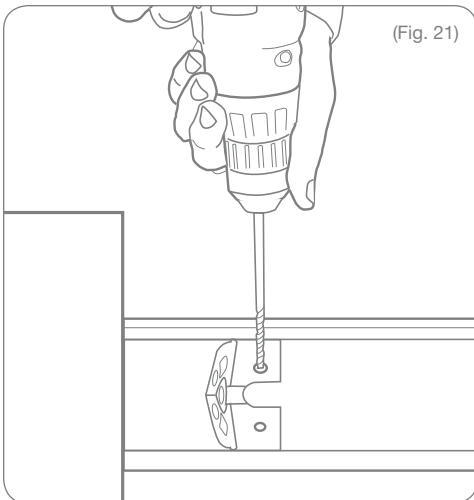
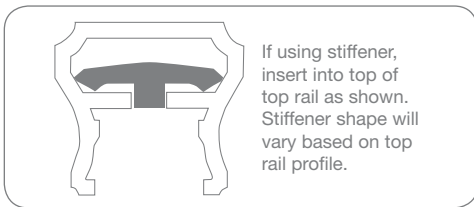

16.

Snap the top rail (component A) onto the top beam (component D) by applying downward pressure. Work from the bottom of the stair to the top end of the rail until the full length of the cover locks into place (Fig. 22 & Fig. 23).

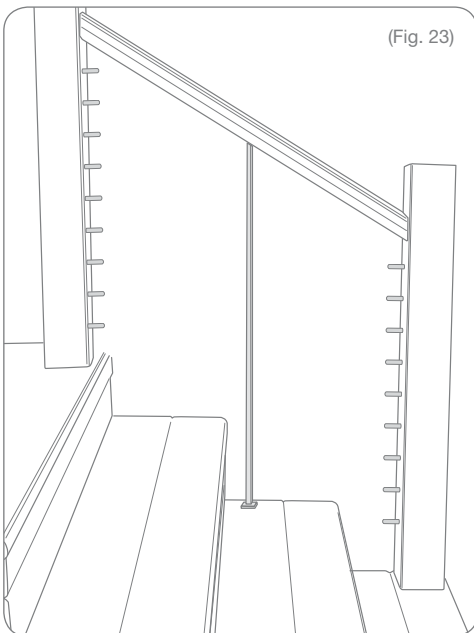
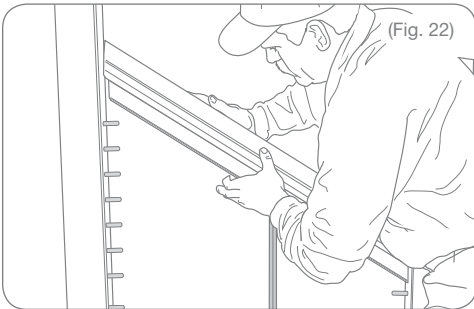

17.

Using the painted screws (component M) install two of the screws upward from underneath each end through the pre-drilled location (Fig. 24). This will secure the bracket, beam, and top rail together (Fig. 25).

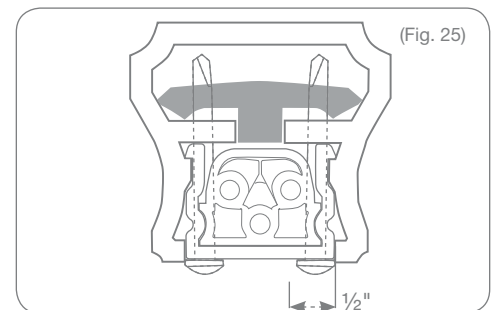
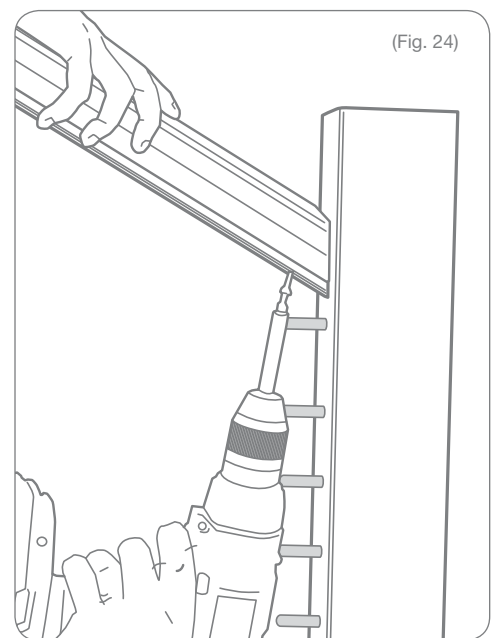

INSTALLING CABLE

17.

All cable cut ends must be clean and burr free. We recommend a Felco type cutter that encircles the cable as it cuts it. When inserting a cut end of the cable into fittings, it is important to rotate the cable and/or fitting in the direction that is “with the lay” of the strand to avoid “unraveling” the cable strands.

Insert cut cables into fittings approximately $1 \frac{1}{16}$ " until you feel it rest against a hard stop (Fig. 26), then pull against the fitting to secure the wedges in the fitting (Fig. 27).

NOTE: Full insertion of the cable is CRITICAL to fitting performance under tension! Cable CAN be removed at this point using the cable release key (sold separately, item 73025484).

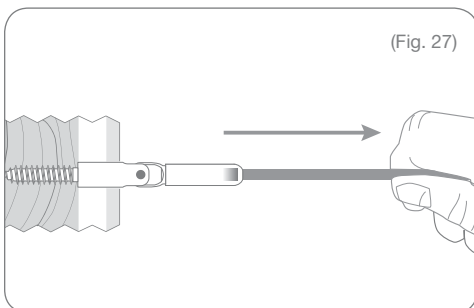
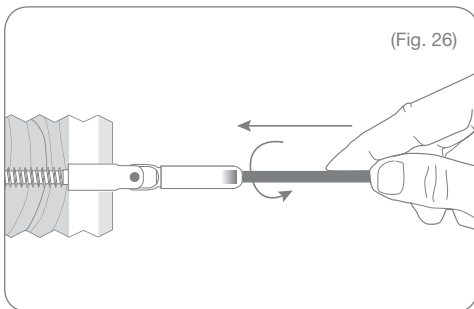

18.

Once the cable is locked into one end of the fitting, feed the other end through the mid-baluster support (required for cable spans over 42" long) (Fig. 28).

Pull the cable taut alongside the extended lag with tensioner, and mark the cable at the score line indicated on the body of the tensioner as shown in Figure 29. Use your cable cutters to cut the cable at this mark.

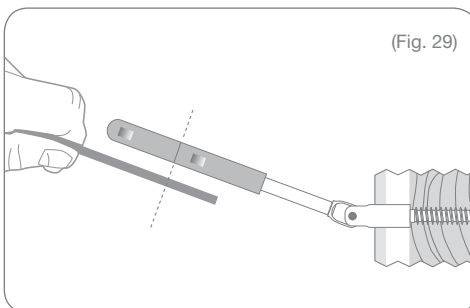
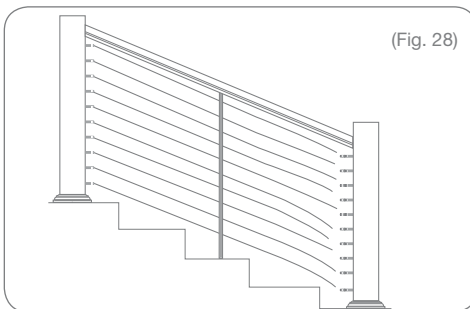

19.

Loosen the tensioner so that approximately 5 or 6 threads are showing and then push the cable into the fitting, twisting the fitting in the direction shown in figure 30. Once the cable has bottomed out in the fitting, pull the cable away from the post to help set the locking mechanism to lock the cable into the fitting (Fig. 31)

NOTE: Full insertion of the cable is CRITICAL to fitting performance under tension! Cable CAN be removed at this point using the cable release key (sold separately, item 73025484).

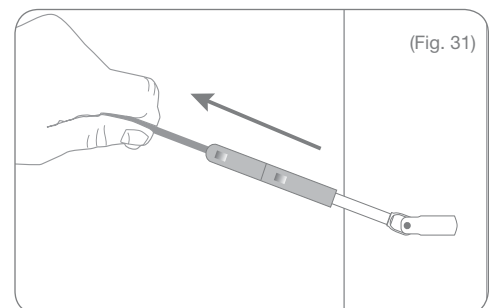
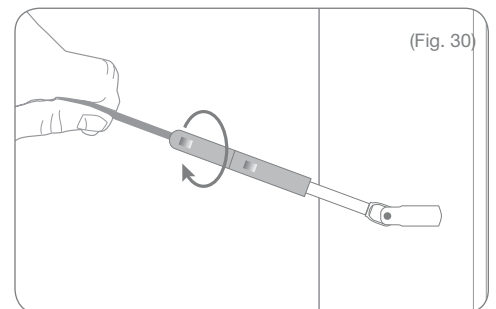

To obtain and review a copy of the warranty please go to: www.rdirail.com/warranty. You can also contact **877.420.7245** or write to **Warranty Registration - RDI, 545 Tilton Road, Egg Harbor City, NJ 08215** to obtain a copy of the warranty.

20.

Tension the cable by holding the cable-gripping portion of the fitting stationary (Fig. 32 – a), using a $\frac{3}{8}$ " wrench as you rotate the female threaded portion of the fitting with a separate $\frac{3}{8}$ " wrench (Fig. 32 – b).

Tension all the cables to desired amount in sequence, beginning with the bottom cable, then the top, then second up from the bottom, then second down from the top and so forth (Fig. 33). Number of cable runs will be determined by finished rail height and optional use of bottom rail.

NOTE: Cable can NOT be removed once tensioned!

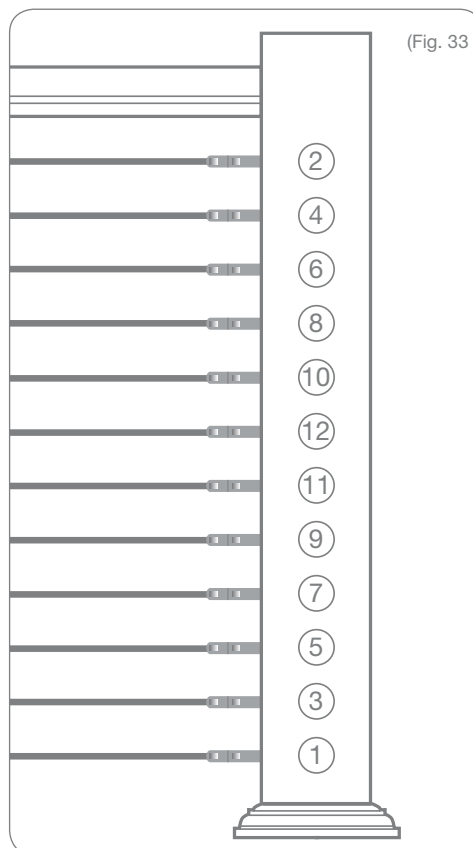
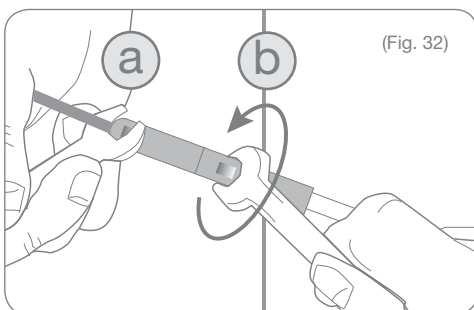

To obtain and review a copy of the warranty please go to: www.rdirail.com/warranty.

You can also contact **877.420.7245** or write to:

Warranty Registration - RDI, 545 Tilton Road, Egg Harbor City, NJ 08215 to obtain a copy of the warranty.

Need a little help installing your railing?
www.rdirail.com/support/installation-videos.html



FOR HOME, FOR LIFE®

545 TILTON ROAD
EGG HARBOR CITY, NJ 08215

TEL: (877) 420-7245
FAX: (866) 277-5160
E-MAIL: CS@RDIRAIL.COM
URL: WWW.RDIRAIL.COM

transform™

MADE BY
Barrette

34107784
REV. 06-18