

# General Notes

1. This drawing emphasizes the TMR pitched flashing VELUX SUN TUNNEL Skylight. It illustrates a general arrangement layout (plus recommendations) for a VELUX TMR installation in a 14–60 degree roof pitch application utilizing either a suspended acoustical tile or grid ceiling installation.
2. The architectural/structural design and specifications for the inclusion of a tubular daylighting device, such as the VELUX TMR, in any roofing/ceiling application is determined and provided by others. The design criteria includes, but is not limited to design loads, structural configurations, structural framing member sizes and material, architectural finishes and integration with the roofing/ceiling systems of the building. VELUX assumes no responsibility or liability in the design, construction and performance of a building structure by others.
3. Dimensions shown are nominal, unless indicated otherwise.
4. TMR 010 0000 nominal diameter is 10". TMR 014 0000 nominal diameter is 14".
5. Maximum tunnel length is 20'. Minimum tunnel length is 16".
6. Ceiling rough opening cut for 010 = 10 $\frac{3}{4}$ ", 014 = 14 $\frac{3}{4}$ ".
7. Minimum 1 1/4" clearance requires **A** around ceiling rough opening, to fit trim ring.



# TMR Components

## TMR 014 0000/TMR 010 0000

- Acrylic Dome
- Counter flashing assembly
- Top collar (16"/.41m)
- Hardware bag

- Option
  - TMR 014 1000/TMR 010 1000 Impact Polycarbonate dome

- 24"/.61m Rigid tunnel
- (2) 11.5"/.29m Rigid elbows
- Tape for tunnel joints
- Hardware bag
- Ceiling ring assembly with crackle over frosted diffuser
- Gasket material for diffuser
- Hardware bag

- Options
  - ZTC 014 0002US-Prismatic diffuser
  - ZTC 014 0003US-Fresnel diffuser

## Option: ZTC 014/ZTC 010 0041US Energy kit

- Residential energy kit (Heat shield & quad diffuser)

## Option: ZTR 014/ZTR 010 Tunnel sections

- ZTR 014 0002 24"/0.61m Rigid tunnel
- ZTR 014 0004 48"/1.22m Rigid tunnel
- ZTR 014 0006 72"/1.83m Rigid tunnel

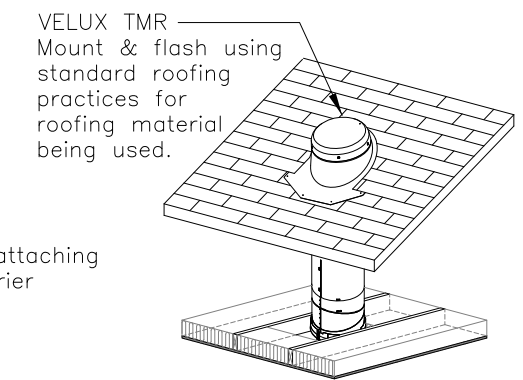
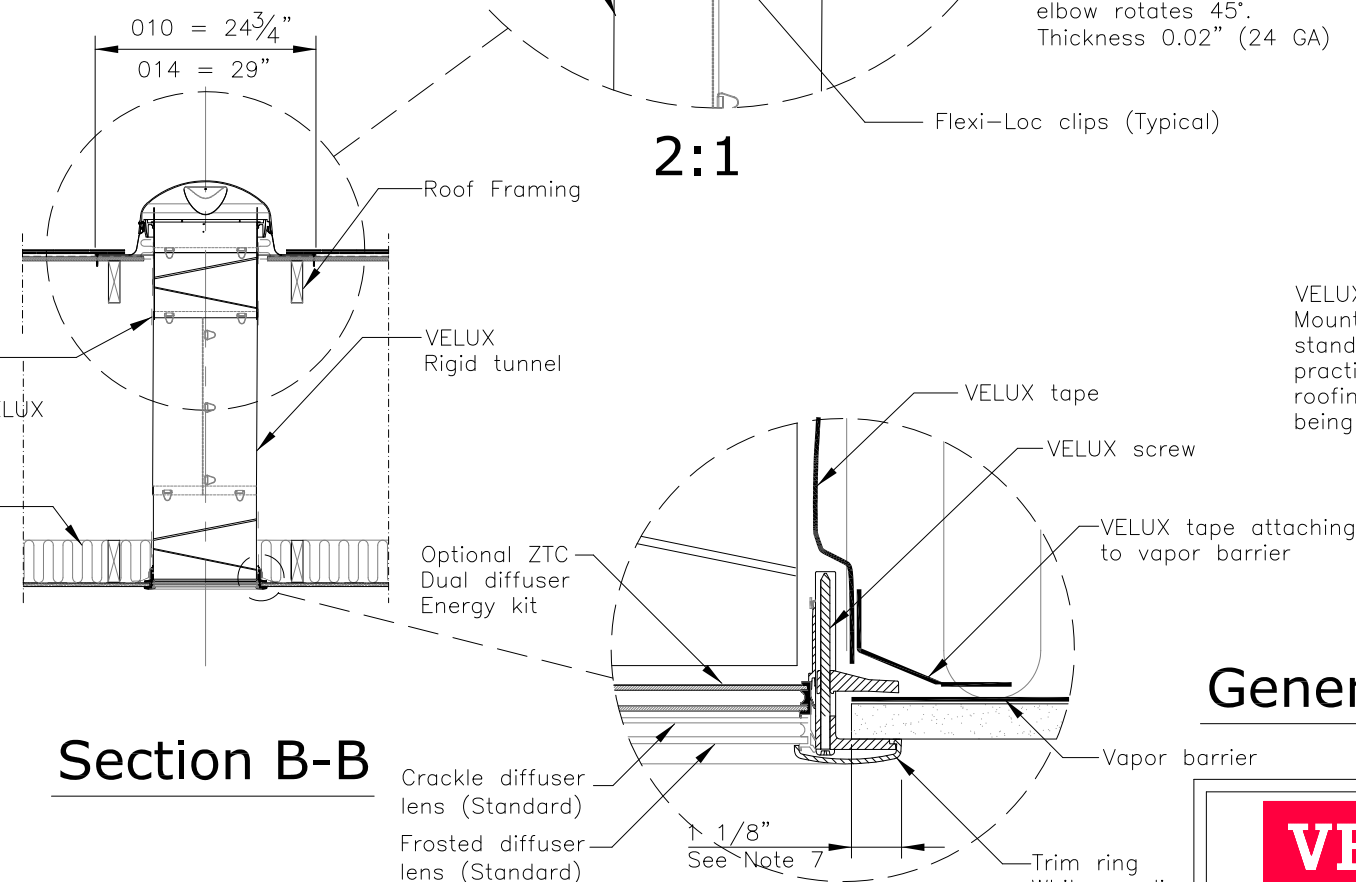
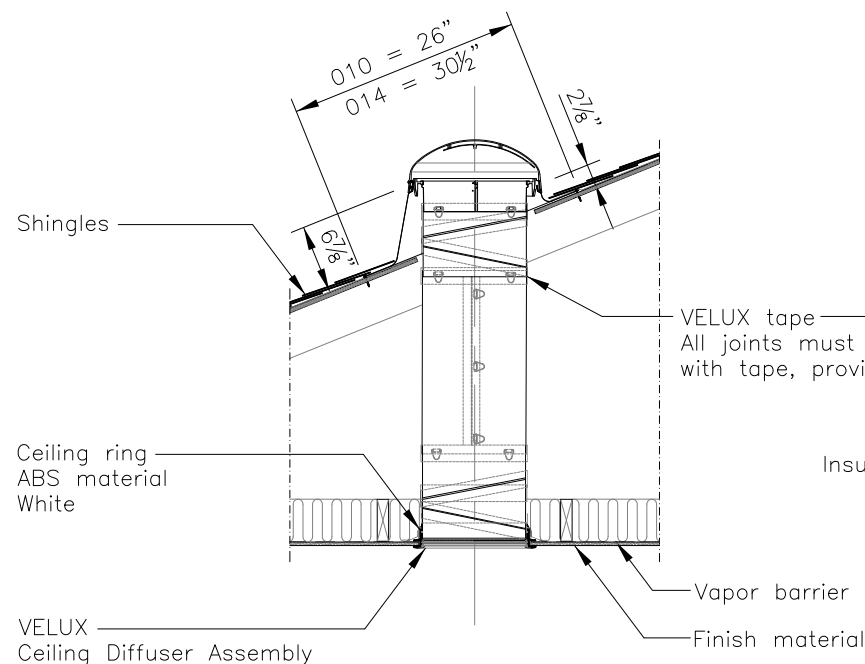
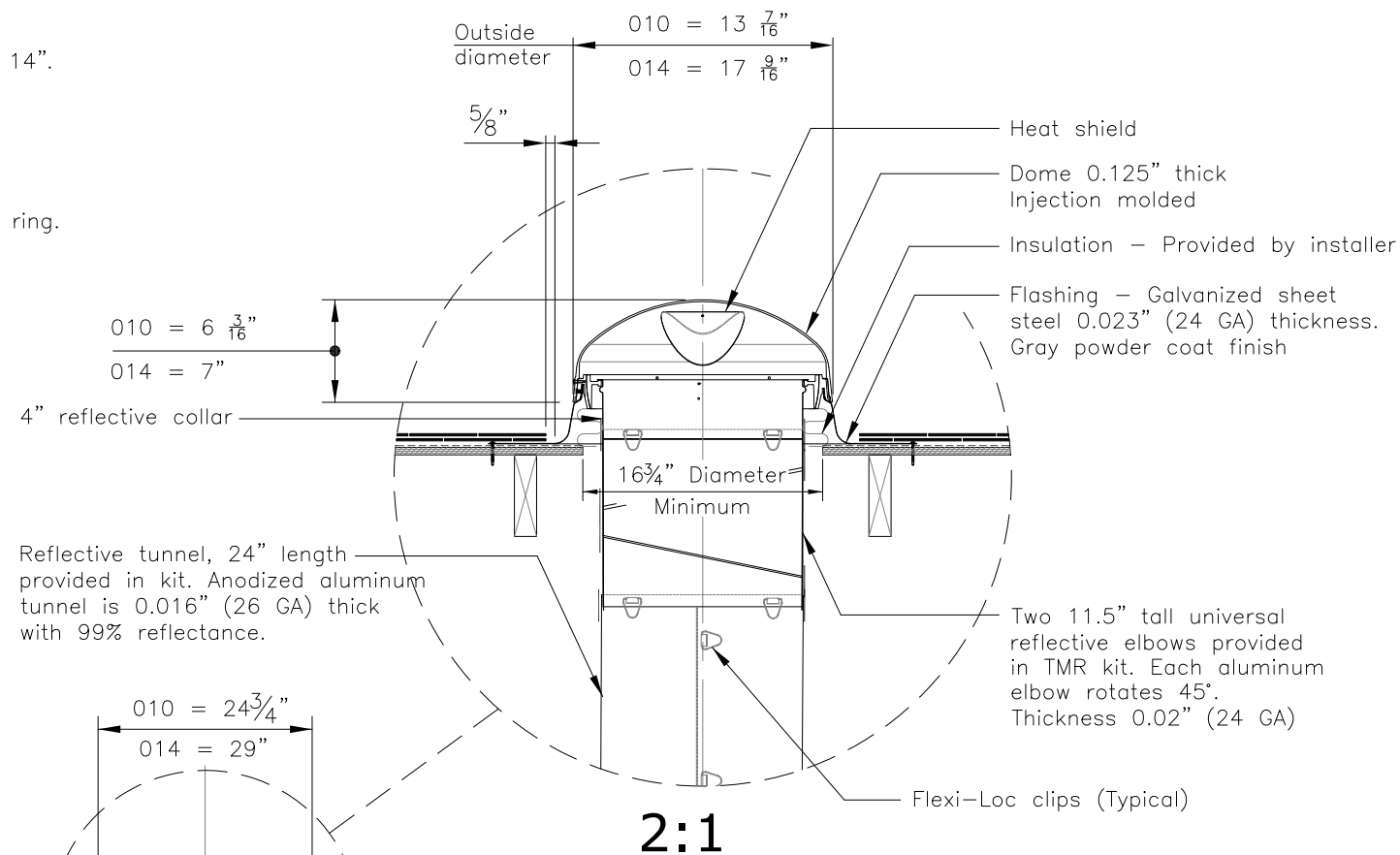
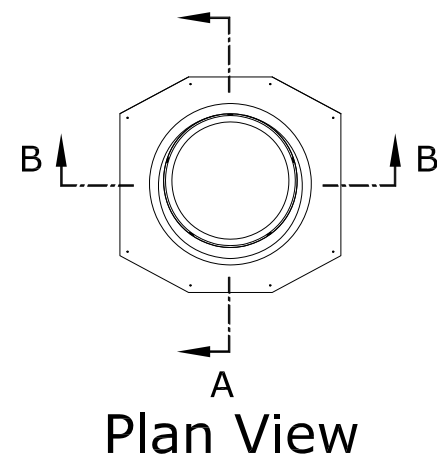

# General Arrangement Layout



Sky-Global Product Management

VELUX  
1418 Evans Pond Road  
Greenwood, SC 29649  
1-800-88-VELUX  
www.VELUXUSA.com

TMR - Residential SUN TUNNEL

This drawing is an instrument of service and is provided for informational use only.