

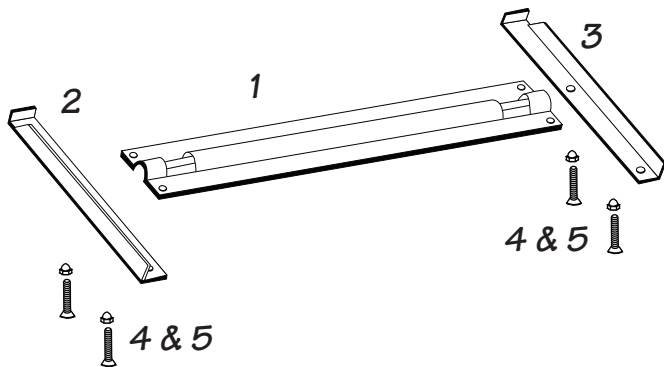

Dock Ladder Speed Release

Part #27271
 Assembly Installation Instructions



This kit contains the following components:

#	Qty.	Part #	Description
1	1	25506	Speed Release Base
2	1	25507L	Speed Release Side Plate Left
3	1	25507R	Speed Release Side Plate Right
4	4	10934	1/4" x 1-1/2" Phillips Flat Head Screw
5	4	10619	Acorn Nut

TOOLS REQUIRED

Flathead screwdriver, 7/16" wrench, hand or power drill, and a 1/4" drill bit.

ASSEMBLY INSTRUCTIONS

1. Attach the Speed Release side plates under the bottom of the ladder braces as shown in the picture, using the 1/4" x 1-1/2" Phillips flat head screws and acorn nuts. Acorn nuts are used on the top. Make sure that the side flanges are located to the outside edge of the ladder brace. Do not tighten at this time. Using the Speed Release base as a guide, make sure the tabs are centered in the base openings. Now tighten the acorn nuts.
2. Before attaching the ladder to the dock, check for obstructions under the dock where the bolt holes will be drilled. Should you have a floating dock, make sure the ladder will not be damaged in fluctuating water levels. The ladder should be flush against the top side of the dock with the Speed Release base attached to the ladder. To mark the holes, use the base plate as a template. Drill four holes using your 1/4" drill bit. Attach ladder to dock with the four 1/4" x 4" stove bolts not included, but supplied with the dock ladder.

IMPORTANT:

LADDER WILL FALL INTO WATER IF NOT BOLTED TO THE DOCK. BE CAREFUL WHEN USING LADDER TO MARK HOLES. SET LADDER COMPLETELY ON TOP OF DOCK AFTER USING TO MARK THE HOLES TO BE DRILLED.

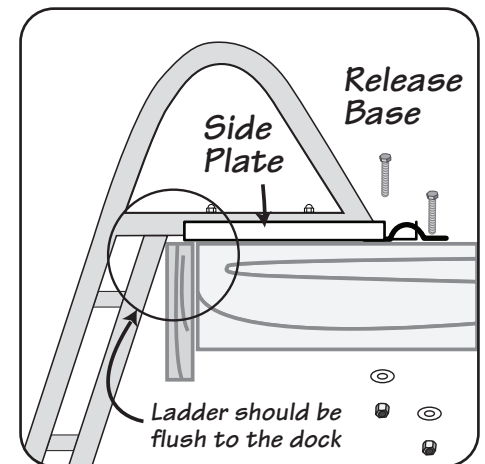
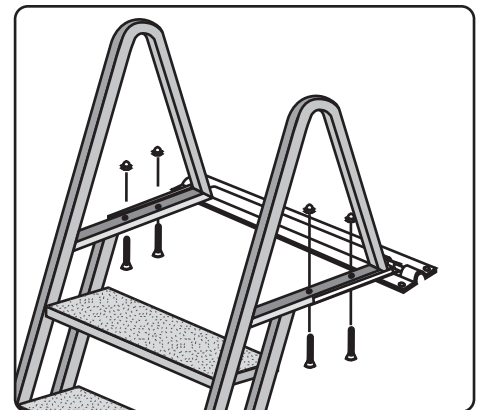

Speed Release/Dock Placement

