

10" Left Tilt Contractor Saw



Operator's Manual

Record the serial number and date of purchase in your manual for future reference.

Serial Number: _____ Date of purchase: _____

For technical support or parts questions, email techsupport@rikontools.com or call toll free at (877)884-5167

TABLE OF CONTENTS

Safety Rules	2-5
Unpacking	5
Assembly	6-13
Installation	13-14
Operation	14-20
Maintenance.....	20
Troubleshooting.....	21
Parts Illustrations, Lists and Notes.....	22-30
Warranty.....	31

SAFETY RULES

WARNING: For your own safety, read all of the instructions and precautions before operating tool.

PROPOSITION 65 WARNING: Some dust created by using power tools contain chemicals known to the state of California to cause cancer, birth defects or other reproductive harm.

Some examples of these chemicals are:

- Lead from lead-based paints.
- Crystalline silica from bricks and cement and other masonry products.
- Arsenic and chromium from chemically-treated lumber.

Your risk from these exposures vary, depending on how often you do this type of work. To reduce your exposure to these chemicals: work in a well ventilated area and work with approved safety equipment. Always wear OSHA/NIOSH approved, properly fitting face mask or respirator when using such tools.

CAUTION: Always follow proper operating procedures as defined in this manual — even if you are familiar with use of this or similar tools. Remember that being careless for even a fraction of a second can result in severe personal injury.

BE PREPARED FOR THE JOB

- Wear proper apparel. Do not wear loose clothing, gloves, neckties, rings, bracelets or other jewelry which may get caught in moving parts of machine.
- Wear protective hair covering to contain long hair.
- Wear safety shoes with non-slip soles.
- Wear face mask or dust mask if operation is dusty.

- Wear safety glasses complying with United States ANSI Z87.1. Everyday glasses have only impact resistant lenses. They are **NOT** safety glasses.
- Be alert and think clearly. Never operate power tools when tired, intoxicated or when taking medications that cause drowsiness.

PREPARE WORK AREA FOR JOB

- Keep work area clean. Cluttered work areas invite accidents.
- Do not use power tools in dangerous environments. Do not use power tools in damp or wet locations. Do not expose power tools to rain.
- Work area should be properly lighted.
- Keep visitors at a safe distance from work area.
- Keep children out of workplace. Make workshop childproof. Use padlocks, master switches or remove switch keys to prevent any unintentional use of power tools.
- Keep power cords from coming in contact with sharp objects, oil, grease and hot surfaces.

TOOL SHOULD BE MAINTAINED

- Always unplug tool prior to inspection.
- Consult manual for specific maintaining and adjusting procedures.
- Keep tool lubricated and clean for safest operation.
- Remove adjusting tools. Form habit of checking to see that adjusting tools are removed before switching machine on.
- Keep all parts in working order. Check to determine that the guard or other parts will operate properly and perform their intended function.
- Check for damaged parts. Check for alignment of moving parts, binding, breakage, mounting and any other condition that may affect a tool's operation.
- A guard or other part that is damaged should be properly repaired or replaced. Do not perform makeshift repairs. (Use parts list provided to order replacement parts.)
- Maintain proper adjustment of rip fence and blade guard.
- Never adjust saw while running. Disconnect power to avoid accidental start-up.
- Have damaged or worn power cords replaced immediately.
- Keep blade sharp for efficient and safest operation.

KNOW HOW TO USE THE TOOL

- Use right tool for the job. Do not force tool or attachment to do a job for which it was not designed.
- Disconnect tool when changing blade.
- Avoid accidental start-up. Make sure that the tool is in the "off" position before plugging in, turning on safety disconnect or activating breakers.
- Do not force tool. It will work most efficiently at the rate for which it was designed.
- Keep hands away from blade and moving parts and cutting surfaces.
- Never leave tool running unattended. Turn the power off and do not leave tool until it comes to a complete stop.
- Do not overreach. Keep proper footing and balance.
- Never stand on tool. Serious injury could occur if tool is tipped or if blade is unintentionally contacted.
- Know your tool. Learn the tool's operation, application and specific limitations.

- Handle workpiece correctly. Press firmly against table. Protect hands from possible injury.
- Turn machine off if it jams. Blade jams when it digs too deeply into workpiece. (Motor force keeps it stuck in the work.)
- Feed work into the blade only as recommended in "Operation."

WARNING: For your own safety, do not operate your saw until it is completely assembled and installed according to instructions.

STABILITY OF SAW

If there is any tendency for the saw to tip over or move during certain cutting operations, such as cutting extremely heavy panels or long heavy boards, the saw should be bolted down. If you attach any kind of extensions over 24" wide to either end of the saw, make sure you either bolt the saw to the floor, as appropriate, or support the outer end of the extension from the bench or floor, as appropriate.

LOCATION

The saw should be positioned so neither the operator nor a casual observer is forced to stand in line with the saw blade.

KICKBACKS

A kickback occurs during a rip-type operation when a part or all of workpiece is thrown back violently toward operator.

Keep your face and body to one side of the saw blade, out of line with a possible kickback.

Kickbacks and possible injury from them can usually be avoided by:

- Maintaining rip fence parallel to saw blade.
- Keeping saw blade sharp. Replace or sharpen anti-kickback pawls when points become dull.
- Keeping saw blade guard, spreader, and anti-kickback pawls in place and operating properly. The spreader must be in alignment with the saw blade and the pawls must stop a kickback once it has started. Check their action before ripping.
- Not ripping work that is twisted or warped or does not have a straight edge to guide along the rip fence.
- Not releasing work until you have pushed it all the way past the saw blade.
- Using a push stick for ripping widths less than 6 inches.
- Not confining the cutoff piece when ripping or crosscutting.

PROTECTION: EYES, HANDS, FACE, BODY, EARS

- If any part of your saw is missing, malfunctioning, or has been damaged or broken (such as the motor switch, electronic controls, other operating control, a safety device or power cord), cease operating immediately until the particular part is properly repaired or replaced.
- Wear safety goggles that comply with United States ANSI Z87.1 and a face shield or dust mask if operation is dusty. Wear ear plugs or muffs during extended periods of operation.
- Small loose pieces of wood or other objects that contact the rear of the revolving blade can be thrown back at the operator at excessive speed. This can usually be avoided by keeping the guard and spreader in place for all thru-sawing operations (sawing entirely thru work) and by removing all loose pieces from the table with a long stick of wood immediately after they are cut off.
- Use extra caution when the guard assembly is removed for resawing, dadoing, or rabbeting—replace guard as soon as that operation is completed.
- Never turn the saw ON before clearing the table of all tools, wood scraps, etc., except the workpiece and related feed or support devices for the operation planned.
- Never place your face or body in line with the cutting tool.
- Never place your fingers or hands in path of saw blade or other cutting tool.
- For rip or rip-type cuts, the following end of a workpiece to which a push stick or push board is applied must be square (perpendicular to the fence) in order that feed pressure applied to the workpiece by the push stick or block does not cause the workpiece to come away from the fence, and possibly cause a kickback.
- During rip and rip-type cuts, workpiece must be held down on table and against fence with a push stick, push block, or featherboards, as applicable (see Figures 1a and 1b, page 4).

The push stick and push block examples shown on page 4 are useful for keeping hands and fingers away from saw blade during ripping, rabbeting and dadoing. Apply downward pressure and push workpiece through the cut and past the blades. Several other configurations may be suitable for safe operation.

Featherboards are used to keep the work in contact with the rip fence or table during the cutting operation. Use of featherboards can help to prevent kickbacks and binding. Featherboards should be used for all “non thru-sawing” operations.

- Never reach in back of the cutting tool with either hand to hold down or support the workpiece, remove wood scraps, or for any other reason. Avoid awkward operations and hand positions where a sudden slip could cause fingers or hand to move into a saw blade or other cutting tool.
- Do not perform layout, assembly, or setup work on the table while the cutting tool is rotating.
- Do not perform any operation freehand—always use either rip fence or miter gauge to position and guide the work.
- Never use the rip fence when cross-cutting or the miter gauge when ripping. Do not use rip fence as a length stop. Never hold onto or touch free-end of workpiece or a free-piece that is cut off, while power is ON and/or saw blade is rotating.
- Shut the saw OFF and disconnect power source when removing the table insert, changing the cutting tool, removing or replacing the blade guard, or making adjustments.
- Provide adequate support to the rear and sides of the saw table for wide or long workpieces.
- Plastic and composition materials (like hardboard) may be cut on your saw. However, since these are usually quite hard and slippery, the anti-kickback pawls may not stop a kickback. Therefore, be especially attentive to following proper setup and cutting procedures for ripping. Do not stand, or permit anyone else to stand, in line with a potential kickback.
- If you stall or jam the saw blade in the workpiece, turn saw OFF and remove the workpiece from the saw blade. Check to see if the saw blade is parallel to the miter gauge grooves and if the spreader is in proper alignment with the saw blade. If ripping at the time, check to see if the rip fence is parallel with the saw blade. Readjust as required.
- Do not remove small pieces of cutoff material that may become trapped inside the blade guard while the saw is running. This could endanger your hands or cause kick back. Turn saw OFF and wait until blade stops.
- Use extra care when ripping wood with twisted grain or wood that is twisted or bowed—it may rock on table and pinch saw blade.

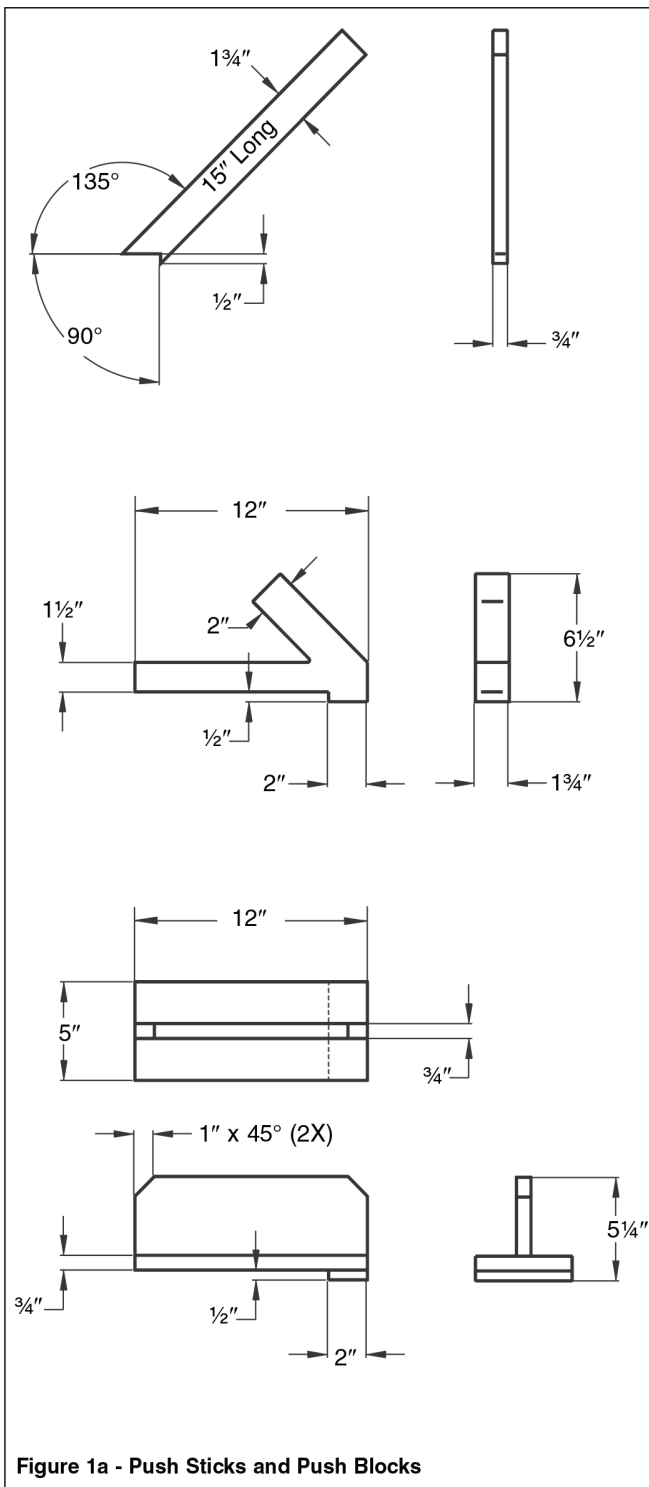

KNOW YOUR CUTTING TOOLS

- Dull, gummy, improperly sharpened or set cutting tools can cause material to stick, jam, stall saw, or kickback at operator. Minimize potential injury by proper care and machine maintenance.

WARNING: Never attempt to free a stalled saw blade without first turning saw OFF.

- Never use grinding wheels, abrasive cutoff wheels, friction wheels (metal slitting blades), wire wheels or buffing wheels.

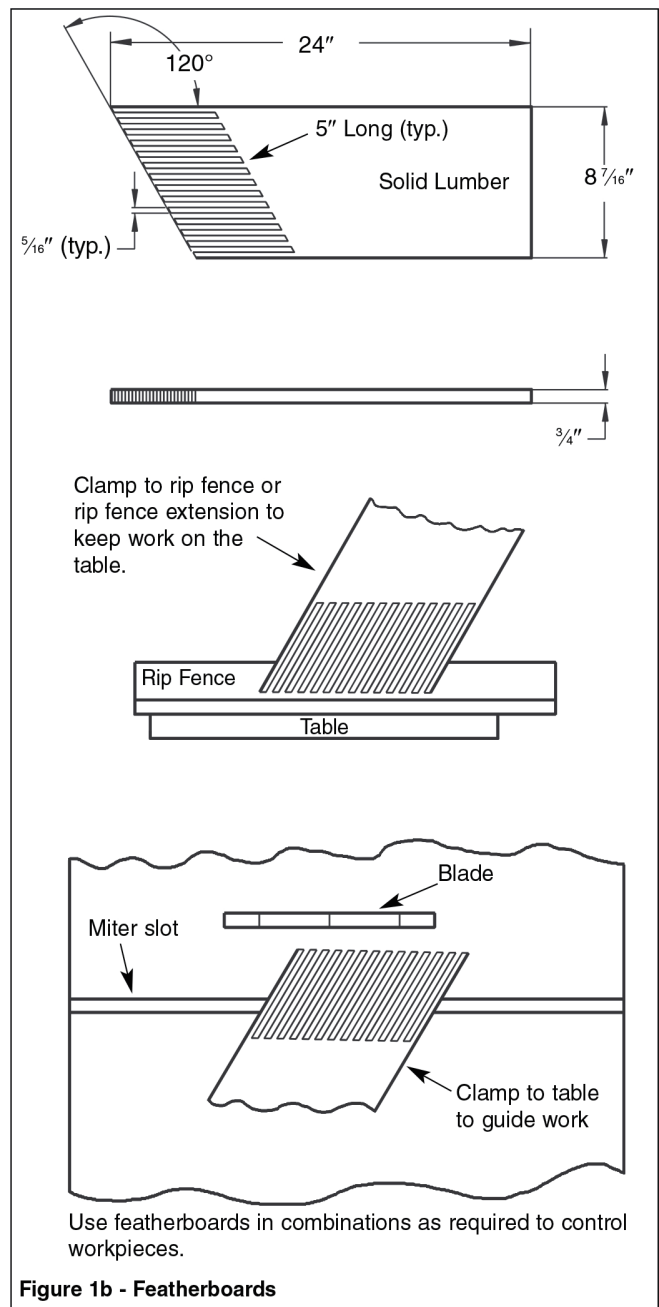

USE ONLY ACCESSORIES DESIGNED FOR SAW

- Crosscutting operations are worked more conveniently and with greater safety if an auxiliary wood facing is attached to miter gauge using holes provided. However, facing must not interfere with proper functioning of saw blade guard.
- Make sure the top of the arbor or cutting tool rotates toward you when standing in normal operating position. Also make sure the cutting tool, blade flange and arbor nut are installed properly. Keep the cutting tool as low as possible for the operation being performed. Keep all guards in place whenever possible.
- Do not use any blade or other cutting tool marked for operating speed less than 4000 RPM. Never use a cutting tool larger in diameter than diameter for which saw was designed. For greatest safety and efficiency when ripping, use maximum diameter blade for which saw is designed, since under these conditions spreader is nearest the blade.

- Adjust table inserts flush with table top. Never operate saw unless proper insert is installed.
- Never feed material into the cutting tool from the rear of the saw. An accident and serious injury could result.

THINK SAFETY

Safety is a combination of operator common sense and alertness at all times when the saw is being used.

Never use another person as a substitute for a table extension, or as additional support for a workpiece that is longer or wider than basic saw table, or to assist in feeding, supporting or pulling the workpiece.

Do not pull the workpiece through the saw blade—position your body at the infeed side of the guard; start and complete the cut from that same side. This will require added table support for long or wide workpieces that extend beyond the length or width of the saw table.

CAUTION: Follow safety instructions that appear on the front of your saw.

UNPACKING

Refer to Figure 2.

- Open shipping box. Remove all parts, except saw body, from both styrofoam packing bases and set parts and top base safely aside. Remove the dust chute from the saw cabinet.
- Use utility knife to cut down the four corners of the shipping box, allowing cardboard sides to lay on floor and fully exposing the styrofoam packing base.
- Cut away enough styrofoam from motor cover side of packing base so that, with the aid of an assistant, you can slide the saw body from the base onto cardboard. Saw table will remain on cardboard until instructed in Assembly section to turn saw body upright onto leg base.

CAUTION: Do not attempt assembly if parts are missing. Use this manual to order replacement parts.

Check for shipping damage or missing parts. If any parts are damaged or missing, call 1-877-884-5167 for replacements.

The table saw body comes assembled as one unit. Additional parts which need to be fastened to the saw should be located and accounted for before assembling:

1. Table saw
2. Extension table (2)
3. Brace
4. Table insert
5. Dust chute
6. Rip fence assembly
7. Miter gauge assembly
8. Front rail (2)
9. Rear rail (2)
10. Handwheel with knob (2)
11. Rip fence storage hooks (2)
12. Blade guard storage hooks (2)
13. Push stick storage hooks (2)
14. Line cord wrap hooks (2)
15. Caster (4)
16. Foot (4)
17. Anti-kickback pawl assembly
18. Blade guard assembly
19. Push stick
20. Link plate
21. Front caster support assembly
22. Rear caster support assembly
23. Corner support (4)
24. Base panel "A" (2)
25. Base panel "B"
26. Base panel "C"

Hardware Bag #1 (For extension table assembly)

- M10X25 Socket head bolt (6)
- 10mm Lock washer (6)
- 10mm Flat washer (6)

Hardware Bag #2 (For guide rail and brace assembly)

- M8X30 Hex head bolt (16)
- M8X16 Hex head bolt (4)
- 8mm Lock washer (20)
- 8mm Flat washer (20)
- M8 Hex nut (16)
- M8 Acorn hex nut (4)

Hardware Bag #3 (For switch assembly)

- M6X16 Hex head bolt (2)
- 6mm Flat washer (2)
- 6mm Lock washer (2)
- M6 Hex nut (2)

Hardware Bag #4

- M10X25 Socket head bolt (4)
- 10mm Lock washer (4)
- 10mm Flat washer (4)
- (For assembling stand to main machine)

- M8X16 Socket pan head screw (8)
- (For assembling caster supports to corner support)

- M6X12 Socket pan head screw (24)
- (For assembling corner support to base panel)

- M6X20 Socket pan head screw (4)
- 6mm Flat washer (4)
- M6 Hex nut (4)
- (For assembling fence storage hooks and line cord hooks)

- M4X8 Pan head screw (8)
- (For assembling push stick storage and blade guard storage hooks)
- 4mm Flat washer (8)

Hardware Bag #5

- 10/13mm Open end wrench
- 4mm Hex wrench
- 6mm Hex wrench
- 5mm Hex wrench
- 8mm Hex wrench

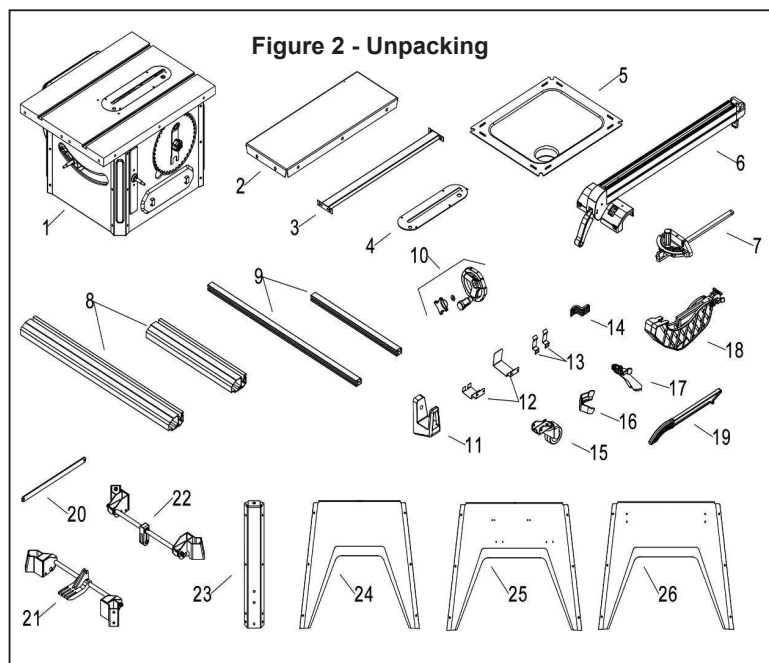

ASSEMBLY

CAUTION: Do not attempt assembly if parts are missing. Use this manual to order replacement parts. Be certain all parts are clean and free of shipping preservative. Also, completely remove all parts of packing. Saw cabinet should be assembled directly on the floor.

SAW INSTALLATION

Positioning the saw on a level surface will improve stability and accuracy and prevent warpage and failure of cast components and welds.

WARNING: Make certain that the saw is disconnected from the power source.

INSTALL HANDWHEELS

Refer to Figure 3.

- Remove saw cabinet and place upside down on cardboard box or cardboard on floor.
- Place one of the handwheels onto the blade raise/lower shaft located on the front of the cabinet. Align the groove in the back of the handwheel with the pin.
- Thread the washer and locking knob onto the threaded end of the shaft. Do not overtighten or handwheel will not turn.
- Repeat the steps above to assemble the remaining hand wheel and locking knob onto the blade tilt shaft located on the side of the cabinet.

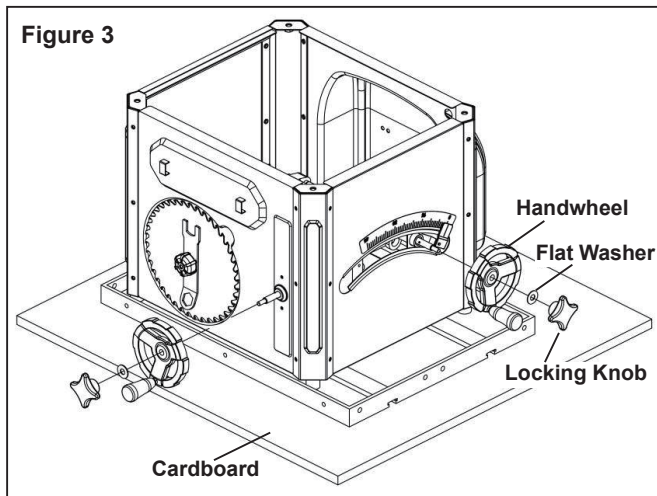

REMOVE PACKING MATERIAL

Refer to Figure 4.

- Use the blade height handwheel to lower the motor.
- Remove the packing material from behind the motor.
- Return motor to the raised position.

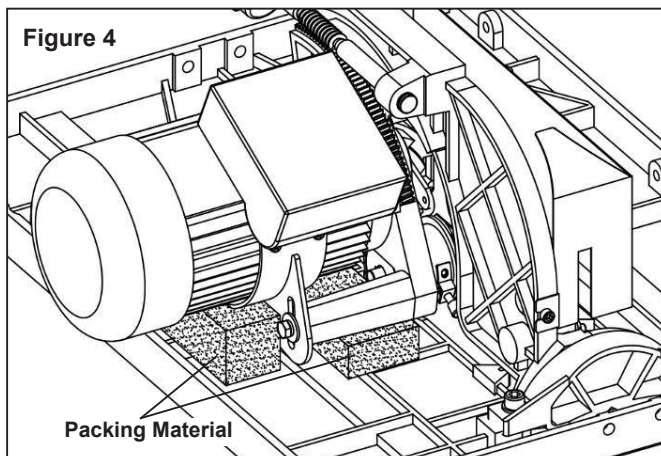

ASSEMBLE MOBILE BASE PANELS

Refer to Figure 5.

Tools Required: 4mm Hex Wrench.

Hardware Required: Twenty-four M6 x 12 socket pan head screws (Hardware bag #4).

- Attach a corner support to each front panel edge with three M6 x 12 socket pan head screws.

NOTE: Place the panel edges INSIDE the corner support surfaces.

NOTE: Front panel and rear panel are both stamped 'A'. Front panel has warning label.

- Repeat above step for the rear panel.

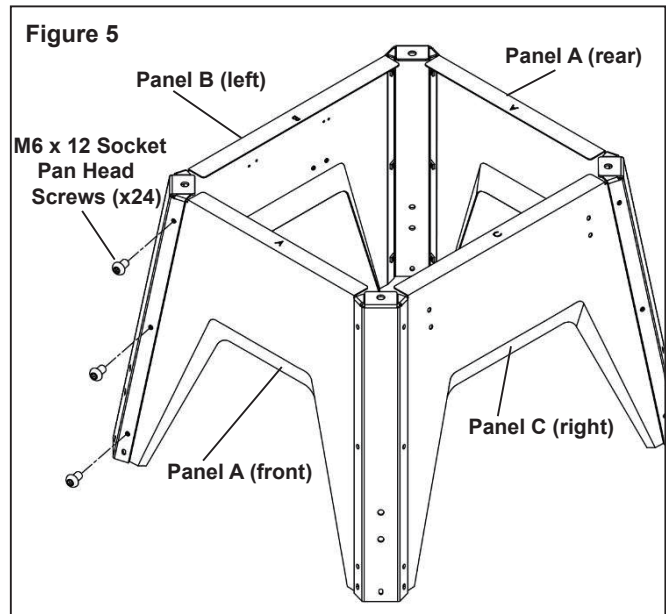

- Turn all panels upside down to perform base assembly.
- Attach one corner of left panel (stamped 'B') to front panel A.
- Attach the other corner of left panel B to rear panel A.
- Repeat above two steps for attachment of right panel (stamped 'C').

ASSEMBLE CASTER SETS

Refer to Figures 6 & 7.

Tools Required: One 6mm Hex wrench and one 13mm Open End or Adjustable Wrenches.

- Remove casters (4), link plate and caster supports (2) from carton.

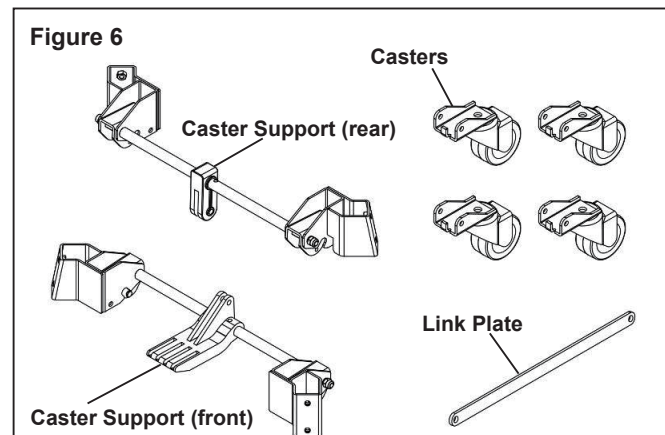

- Loosen and remove the pre-installed bolts and hex nuts from the brackets (see Figure 7).
- Rotate foot pedal bar so that foot pedal is pointing down towards the floor.
- Place casters onto the brackets and secure in position with bolts and hex nuts provided.

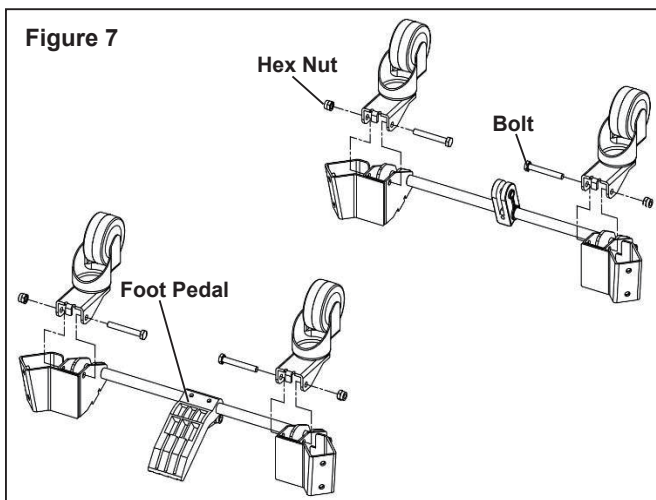

ATTACH CASTER SETS TO BASE

Refer to Figure 8.

Tools Required: Hex wrench 5mm, Hex wrench 6mm and 13mm Open end wrench.

Hardware Required: Eight M8 x 16 socket pan head screws (Hardware bag #4).

- Attach the foot pedal caster set to the two front corner supports using four M8 x 16 socket pan head screws.
- Attach the link block caster set to the two rear corner supports.
- Remove the socket head bolt and hex nut from the foot pedal, insert the link plate into the slot of foot pedal and secure in place with the socket bolt and hex nut.
- Remove the socket head bolt and hex nut from the link block of rear caster set, insert the link plate into the slot of link block and secure in place with the socket bolt and hex nut.

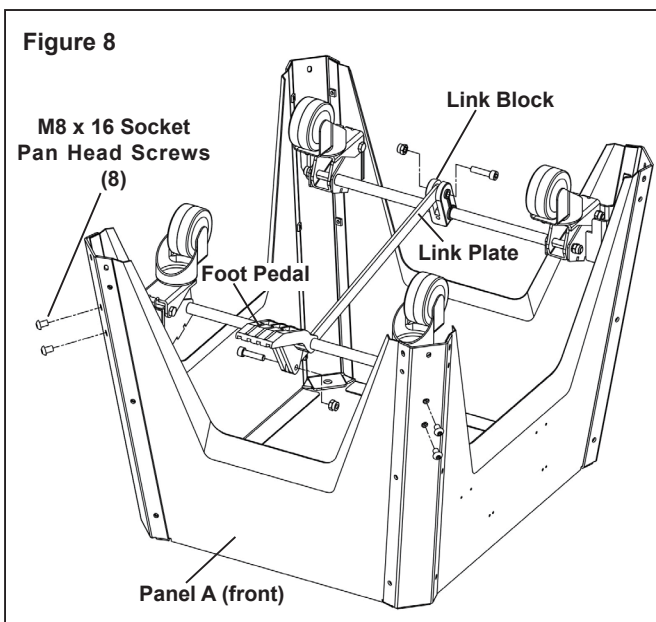

ATTACH CORD WRAP HOOKS

Refer to Figure 9.

Tools Required: Hex wrench 4mm and 10mm open end wrench.

Hardware Required: Two M6 x 20 socket pan head screws, two M6 flat washers and two M6 hex nuts (Hardware bag #4).

- Place cord wrap hook into position on motor housing.
- Insert washer onto bolt. Insert bolt through hole and thread nut onto bolt end on inside of housing.
- Repeat for other hook.

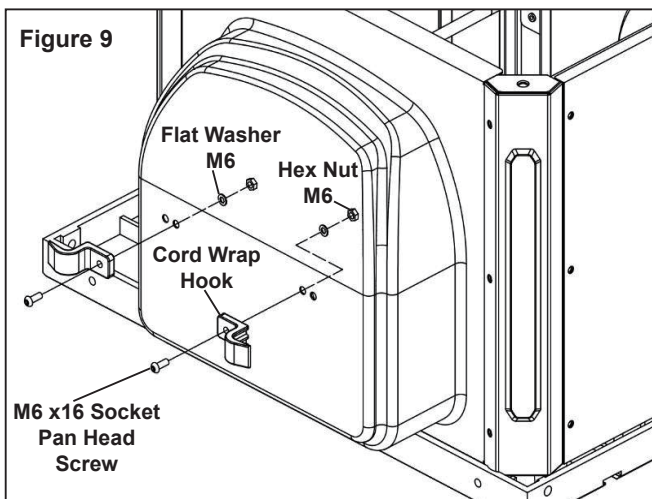

ATTACH BASE TO CABINET

Refer to Figure 10.

Tools Required: 8mm Hex Wrench.

Hardware Required: Four M10 x 25 socket head bolts, four M10 lock washers and four M10 flat washers (Hardware bag #4).

- Place dust chute over the cabinet as shown. Make sure the holes in the corners are aligned with the slots in the dust chute.
- Place the base assembly over the dust chute and secure the base assembly to the cabinet using the flat washers, lock washers and bolts.
- Secure all fasteners in the base assembly fully tight.

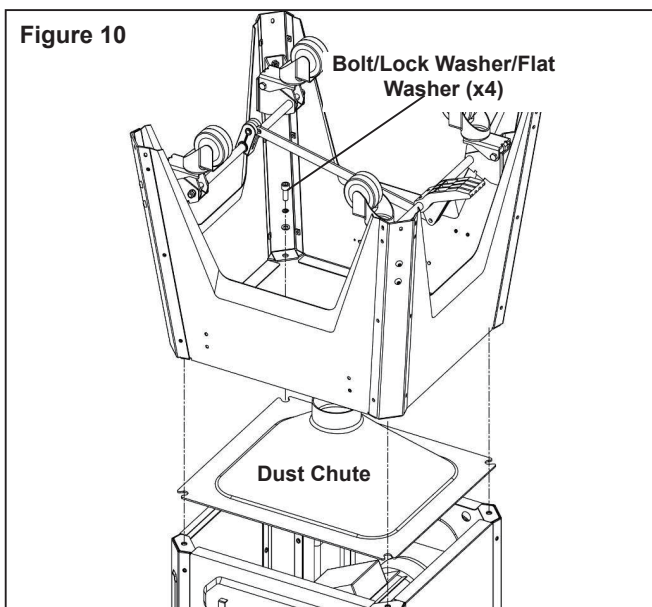

ATTACH RIP FENCE STORAGE BRACKETS

Refer to Figure 11.

Tools Required: 4mm Hex wrench and 10mm Open end wrench.

Hardware Required: Two M6 x 16 socket pan head screws, two 6mm flat washers and two 6mm hex nuts (Hardware bag #4).

- Place rip fence bracket into position against right side panel of cabinet.
- Insert washer onto bolt. Insert bolt through hole and thread nut onto bolt end on inside of panel.
- Repeat for other bracket.

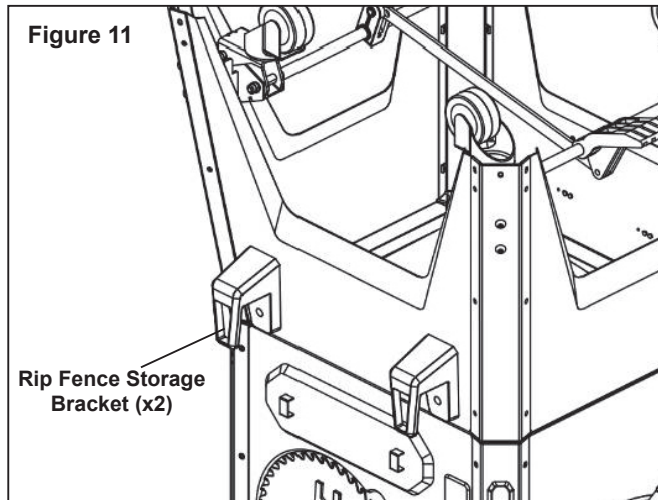

BLADE GUARD, PUSH STICK STORAGE BRACKETS, RUBBER FEET

Refer to Figure 12-1.

Tools Required: Phillips screwdriver.

Hardware Required: Eight M4 x 8 pan head screws, eight 4mm flat washers (Hardware bag #4).

- Install the push stick storage brackets to the left side panel of the base using four M4 x 8 screws, four M4 lock washers and four M4 flat washers.
- Install the blade guard storage brackets to the left side panel of the base using four M4 x 8 screws, four M4 lock washers and four M4 flat washers.

NOTE: Attach the slotted bracket to the front side of the saw.

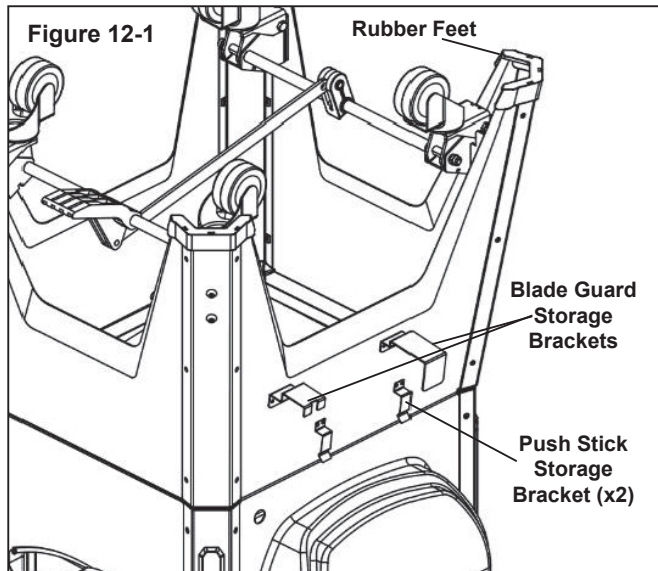

- Press the four molded plastic feet onto the base legs.
- With the aid of an assistant turn the saw upright. First, turn the saw onto the back side. Then raise saw upright onto the base feet.

WARNING: To avoid injury, **Do Not** attempt to turn saw upright by yourself.

TEST CASTER MECHANISM

Refer to Figure 12-2.

Press down on the foot pedal to raise the saw up onto the casters. Move the saw back and forth on the casters to ensure that the mechanism is properly working. Press the foot pedal again to lower the saw onto the floor into a stationary position.

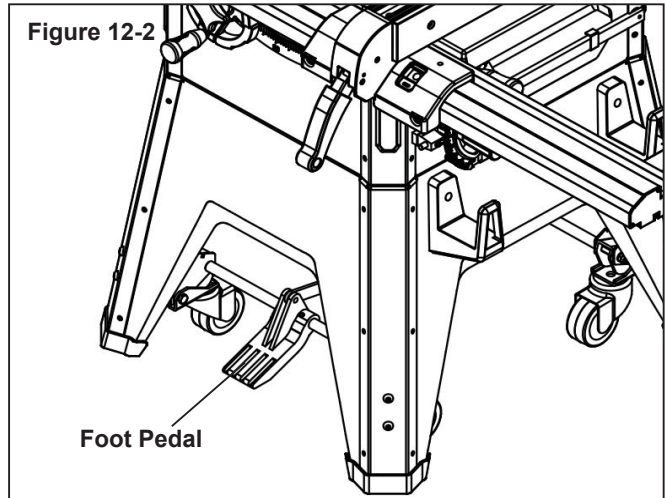

ATTACH EXTENSION TABLES

Refer to Figure 13.

IMPORTANT: Table is coated with a protectant. To ensure proper fit and operation, remove coating. Coating is easily removed with mild solvents, such as mineral spirits, and a soft cloth. Avoid getting solution on paint or any of the rubber or plastic parts. Solvents may deteriorate these finishes. Use soap and water on paint, plastic or rubber components. After cleaning, cover all exposed surfaces with a light coating of oil. Paste wax is recommended for table top.

WARNING: Never use highly volatile solvents. Non flammable solvents are recommended to avoid possible fire hazard.

Tools Required: 8mm Hex Wrench and Straight Edge (not included).

Hardware Required: Six M10 x 25 socket head bolts, six 10mm lock washers and six 10mm flat washers (Hardware bag #1).

- Assemble extension table to the table using socket head bolts, lock washers and flat washers.
- Wipe surface clean.
- Hand tighten only. Do not tighten completely until tables are level. Use a straightedge to level tables.
- Repeat above procedure for the other extension table.
- Use a straight edge to check level and flatness between main and extension tables between main and extension tables along their entire length.
- After tables are adjusted level and flat, secure the extension tables by tightening the bolts completely.

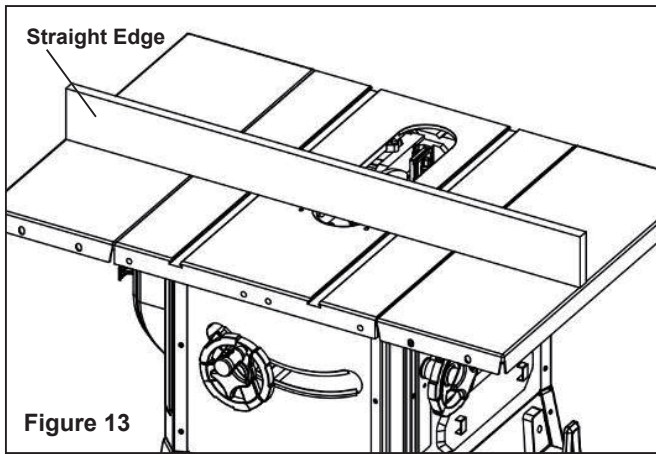

Figure 13

BLADE INSTALLATION

Refer to Figures 14 and 15.

Tools Required: 24mm Open end Wrench.

- Loosen knob on right side of cabinet.
- Remove blade and wrench. Replace knob.
- Ensure the blade assembly is raised all the way up.
- Depress arbor lock and use wrench to loosen flange nut. Remove flange and nut from arbor.

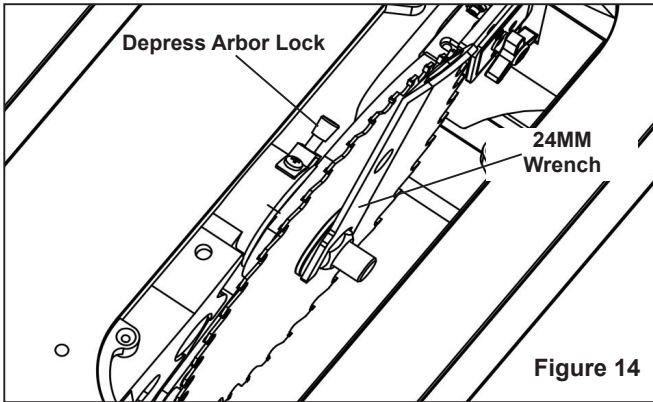

Figure 14

BLADE INSTALLATION Cont.

Refer to Figures 14 and 15.

- Place blade on arbor. Make sure arrow on blade and teeth point towards front of saw.
- Replace flange and nut on arbor. Depress the arbor lock and rotate arbor by hand until arbor locks in place. Keep arbor lock depressed and use 8mm Hex Wrench to fully tighten blade onto arbor.

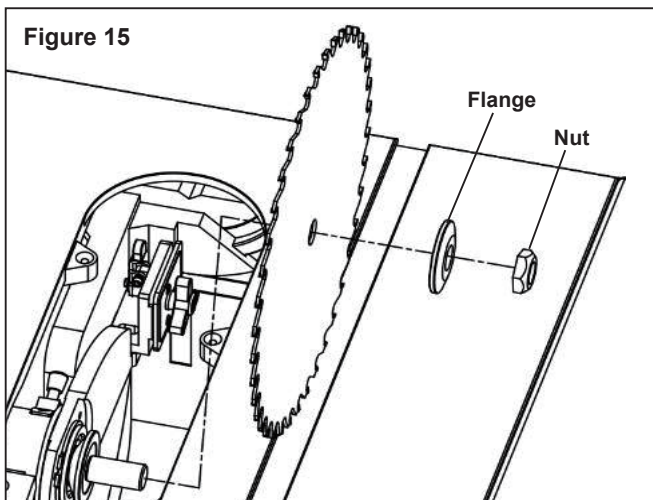

Figure 15

CHECK TABLE ALIGNMENT

Refer to Figures 16, 17 and 18. Pages 9 and 10.

- Saws are shipped from the factory with the table adjusted so the miter gauge slots are parallel to the saw blade. However, in order to obtain the best results from the saw, it is suggested this adjustment be checked before operating.
- A simple method of checking alignment is as follows: Bolt or clamp a dowel rod or similar object to miter gauge (a combination square can be substituted). Pick out a tooth on front of blade and set the dowel to it so it is just touching. Move same tooth to back of blade.

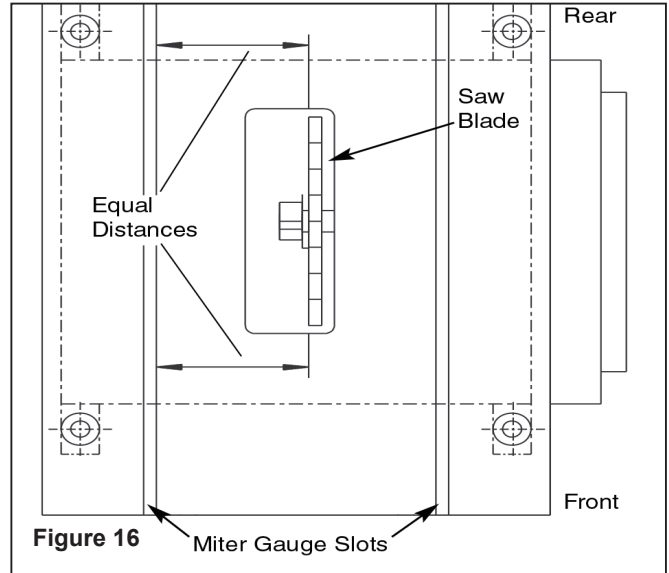

Figure 16

- Gauge this tooth with the dowel rod. If the tooth is in the same position, relative to the miter gauge slot, the table is parallel with the blade. In short, the miter gauge slots must be parallel with the blade. This means that when measuring distance between blade and miter gauge slot at the front and rear of the blade, the distances will be equal (see Figure 16).

NOTE: Be sure to measure the distance or make the test on the same tooth of the saw blade in both front and rear positions.

CHECK TABLE ALIGNMENT Cont.

Refer to Figures 16, 17 and 18. Pages 9 and 10.

- If an adjustment is necessary, proceed as follows: Loosen and remove the six socket pan head screws and the rear panel (see Figure 17). Loosen the four hex head bolts on the trunnion (see Figure 18) and shift trunnions until a position is found where the saw blade is parallel to the miter gauge slots.

NOTE: Saw blade should also be centered within its table insert opening.

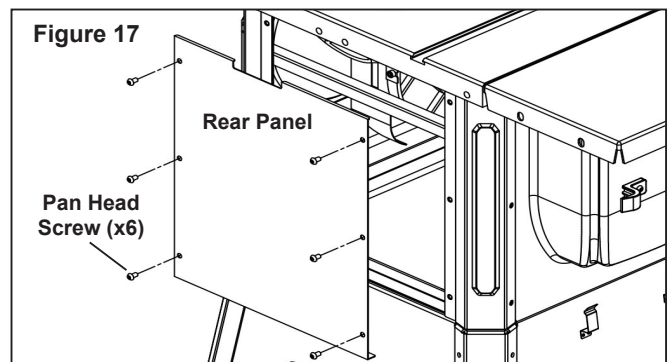
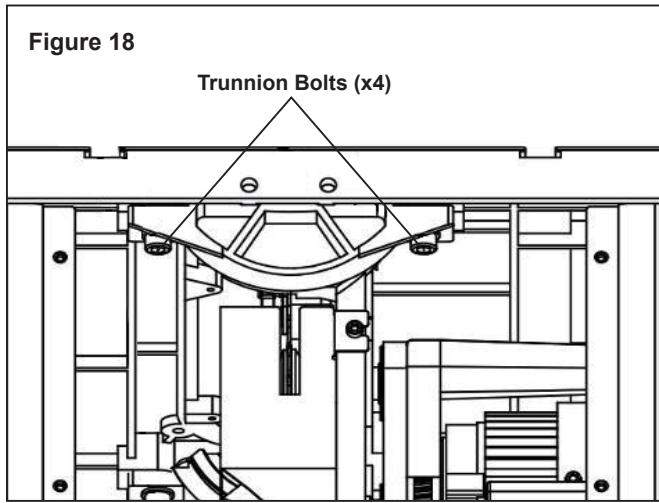

Figure 17



- Tighten the four trunnion hex head bolts and lock washers securely. This procedure will set the table and blade in parallel position and prevent the trunnion from shifting.

NOTE: If you perform this adjustment, leave the back panel off to perform rear rail assembly as described in the next section.

RAIL ASSEMBLY

Refer to Figures on Pages 10 and 11.

Tools Required: 13mm Open end Wrench

Hardware Required: Sixteen M8 x 30 hex head bolts, sixteen 8mm lock washers, sixteen 8mm flat washers and sixteen M8 hex nuts. (Hardware bag #2).

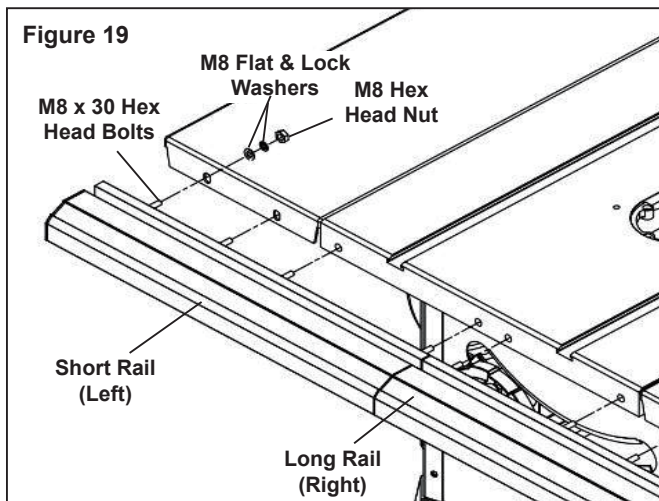

RAIL ASSEMBLY Cont.

Refer to Figures on Pages 10 and 11.

NOTE: For this procedure the longer rail is installed to the right; the shorter rail is installed to the left.

- Assemble the left front rail to the right front rail. Slide the protruding pins from the left rail into the pin slots of the right rail.
- Insert four M8 x 30 hex head bolts into the T-slot of the right front guide rail.
- Insert four M8 x 30 hex head bolts into the T-slot of the left front guide rail.
- Attach the assembled front rail to the table casting and to the right and left table extensions using flat washers, lock washers and hex nuts.

NOTE: Hand tighten all hardware during rail assembly. Do not completely tighten hardware until all rails are mounted.

NOTE: You may have to shift right rail as far right as it will go to attach left rail.

- Position rails so that rails are butted together and the joint between rails is aligned with right side of the blade. You may need a mallet to lightly tap rails together. Make sure rails are completely butted together at the joint.

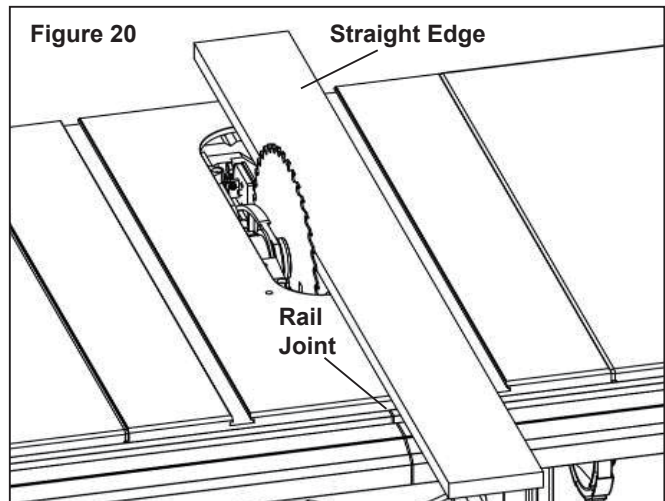

- Use a straight edge to align right edge of rail joint to blade. Fully tighten right rail.
- Use a level to check level and flatness between right and left rail. When level, fully tighten left rail.
- Before proceeding, ensure all hardware is tightly secured.

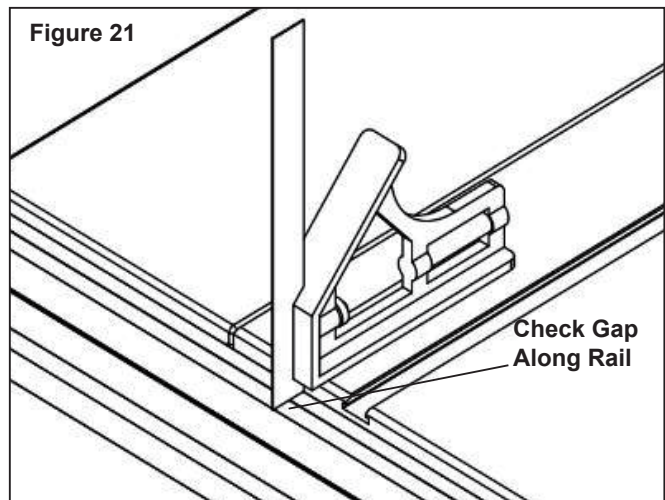

- To allow for attachment of rear rails, loosen and remove the six socket pan head screws and back panel. Figure 23, page 11.
- Install and level the rear rails in the same manner as the front rails. Use a straight edge to align the left edge of rail joint to the blade. Figure 22, page 11.
- Before proceeding, ensure all hardware is tightly secured.
- Replace back panel of the cabinet. Figure 23, page 11.

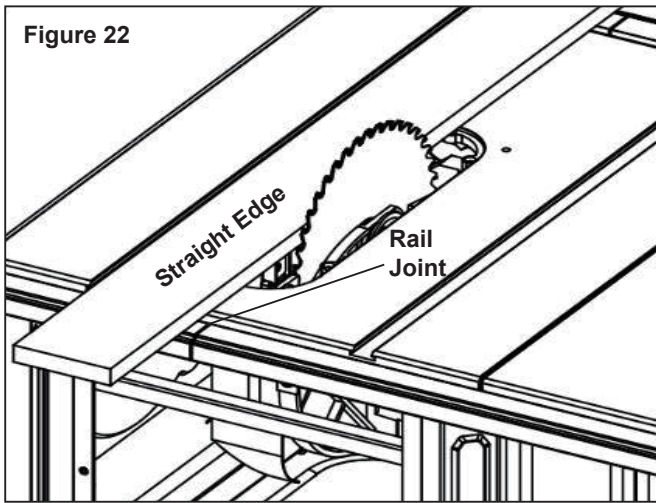

Figure 22

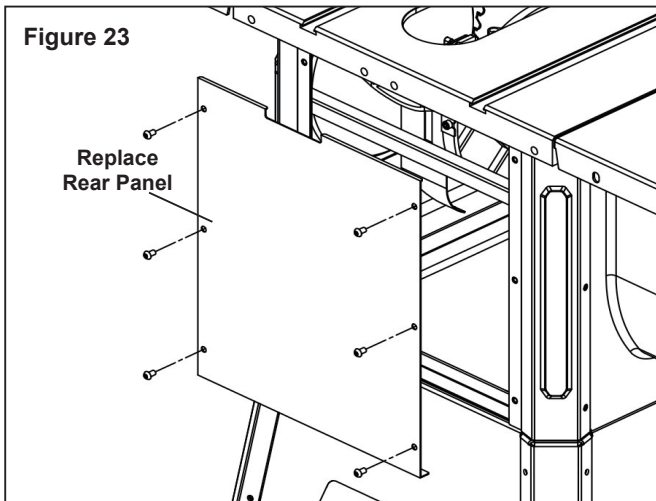

Figure 23

Replace
Rear Panel

RAIL BRACE INSTALLATION

Refer to Figure 24.

Tools Required: 13mm Open end Wrench

Hardware Required: Four M8 x 16 hex head bolts, four 8mm lock washers, four 8mm flat washers and four M8 acorn nuts. (Hardware bag #2).

- Insert four M8 x 16 hex bolts through holes in bracket at each end of brace.
- Attach brace to the far right end of the rails by sliding hex bolts into the rail T-slots. Secure bolts in position with 8mm flat washers, 8mm lock washers and 8mm acorn nuts.

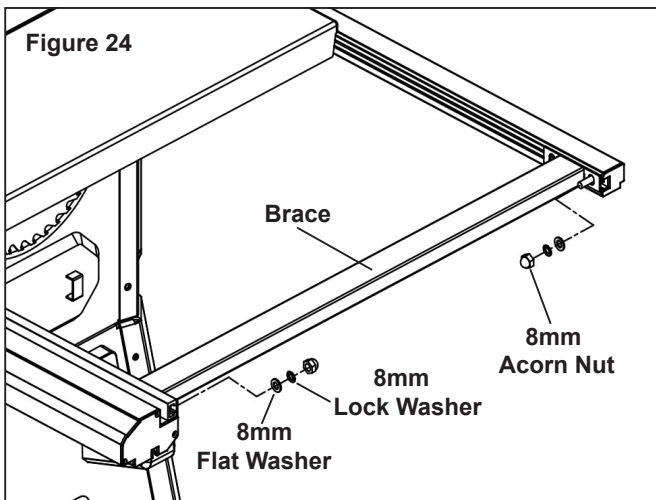

Figure 24

Brace

8mm
Flat Washer

8mm
Lock Washer

8mm
Acorn Nut

ATTACH SWITCH ASSEMBLY

Refer to Figure 25.

Tools Required: 10mm Open end Wrench.

Hardware Required: Two M6 x 16 hex head bolts, two M6 flat washers, two M6 lock washers and two M6 hex nuts. (Hardware bag #3).

- From the top of the switch bracket, insert two bolts through bracket holes.
- Loosely attach flat washer, lock washer and nut to bolts.
- Insert bolt heads into T-slot on bottom of left front rail.
- Slide switch assembly 6" to 8" from left end of rail as shown in Figure 25.
- Fully tighten flat washers, lock washers and hex nuts to secure switch assembly in place.

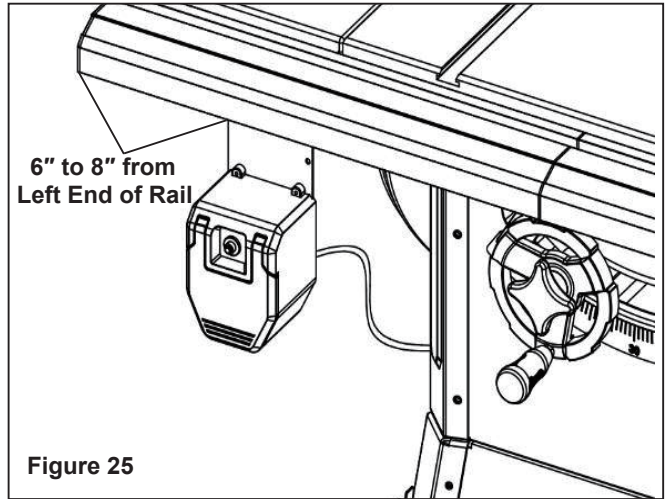

Figure 25

6" to 8"
from
Left End of Rail

RIVING KNIFE POSITION AND ADJUSTMENT

Refer to Figure 26.

- The riving knife is pre-installed on the saw. Raise the blade completely to access the riving knife.
- Loosen the locking knob and raise the riving knife to its highest position. Riving knife has three holes for three positions. The highest position is for all thru cuts. The middle position is for rabbets and other non-thru cuts, (with guard and pawls removed). The lowest position is for dado cuts.

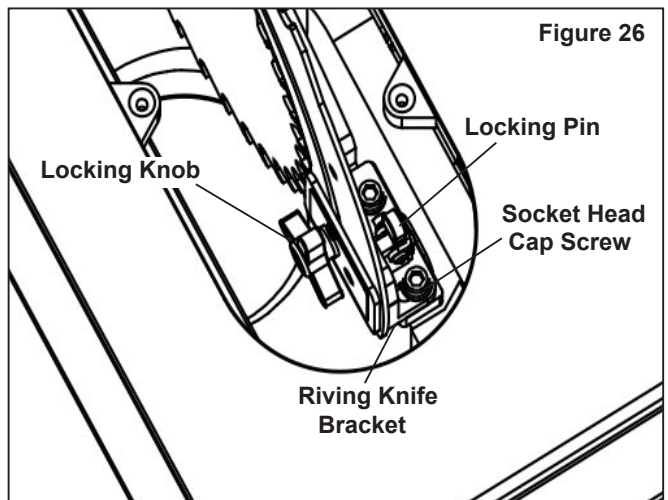

Figure 26

Locking Knob

Locking Pin

Socket Head
Cap Screw

Riving Knife
Bracket

RIVING KNIFE POSITION AND ADJUSTMENTS
CONTINUED ON PAGE 12

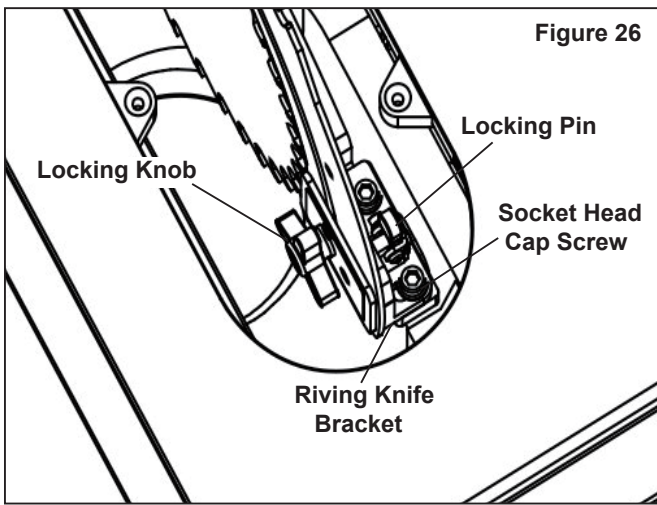

Figure 26

- Make sure locking pin is aligned with riving knife hole and secure in position by tightening locking knob.
- Riving knife must be in line with blade. Make sure riving knife sits flat against mounting bracket and lock plate.

RIVING KNIFE TO BLADE ADJUSTMENT

Refer to Figure 26.

- Riving knife to blade clearance: the gap between the riving knife and the saw blade should be an even distance across the entire radius.
- The riving knife should also be in line with the saw blade. If adjustment is necessary:
 1. Locate the riving knife bracket.
 2. Loosen the two socket head cap screws slightly enough to move the bracket, bringing the riving knife in line with the saw blade. Make sure the gap between the blade and knife is even and from 1/4" to 5/16" in distance.
 3. Once the riving knife is aligned with the blade, tighten the socket head cap screws.

INSTALL TABLE INSERT

Refer to Figure 27.

- Make sure that the riving knife is raised to its highest position.
- Place table insert into throat of table.
- Insert is held in position by magnet in table.
- To adjust insert level with table, adjust leveling screws up or down.

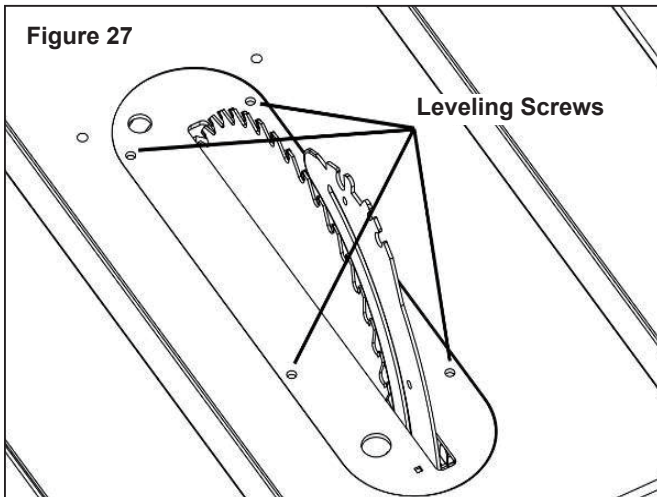

Figure 27

ATTACH BLADE GUARD AND ANTI-KICKBACK PAWLS

Refer to Figures 28-31, pages 12 and 13.

- Place the slot of blade guard body over the riving knife. Slot of bushing is placed in the notch indicated in Figures 28 and 29.
- The bushings have a beveled edge and must be located in the center of the notch to lock properly.
- Position guard completely down on riving knife and press latch to lock in position.
- Blade guard body should be parallel to the table. If not, adjust the 2mm set screws as necessary.
- Place anti-kickback pawl set onto riving knife at notches indicated. The spring pin is placed in the front notch and bolt is placed in the rear notch.
- Press pawl set completely down and press latch to secure in position.

NOTE: The teeth of anti-kickback pawls should touch table surface. Use set screws to adjust if needed.

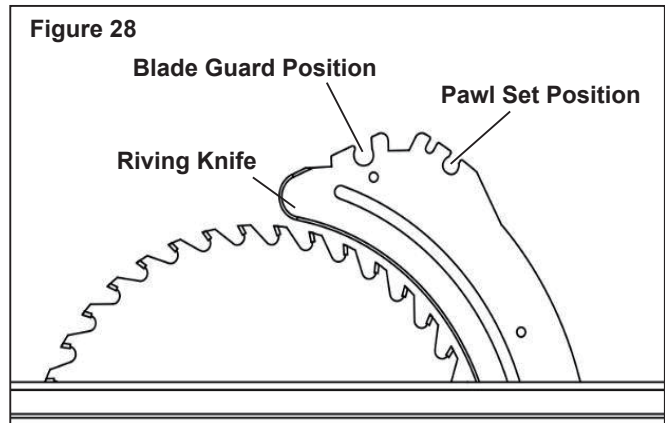

Figure 28

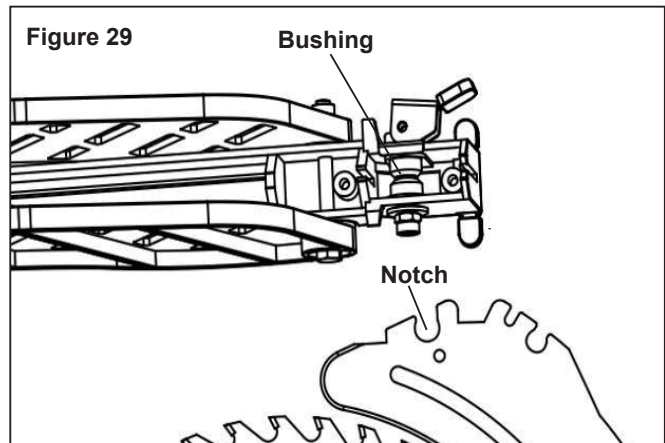

Figure 29

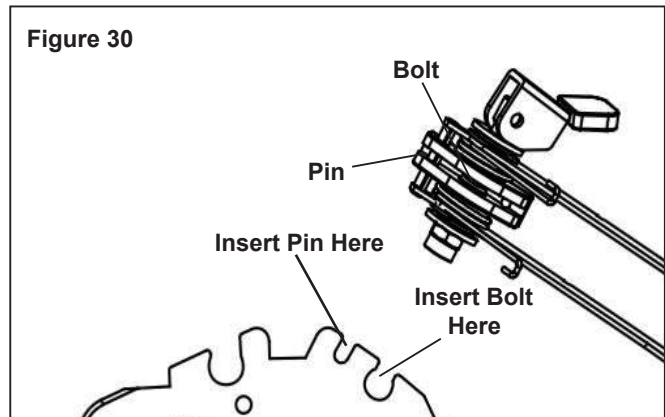
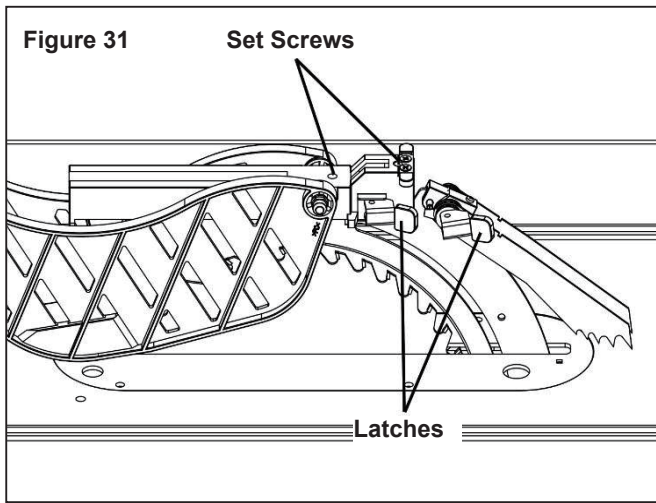

Figure 30



NOTE: The tension of the latch operation for both the Blade Guard and Pawl Set is pre-set at the factory. Adjustment (if needed) can be done by loosening or tightening the 10mm nylon locking nut on the opposite side of each latch.

INSTALL MITER GAUGE AND PUSH STICK

Refer to Figures 32 and 33.

- The miter gauge comes preassembled. Unpack the miter gauge and clean thoroughly. Insert into storage slots on right side of cabinet.
- Insert the push stick into brackets on left side of base.

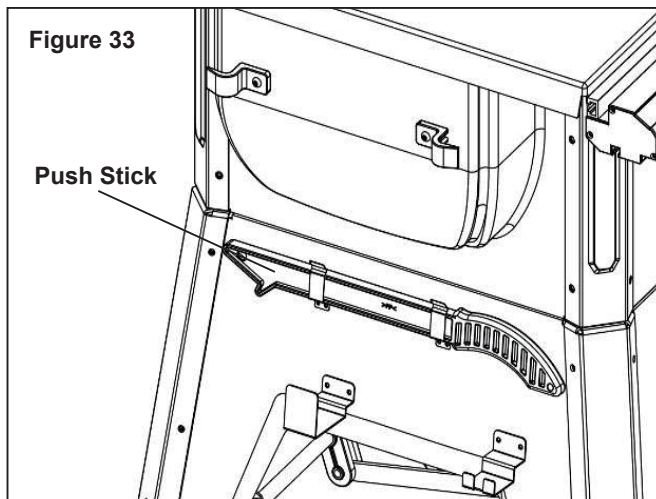
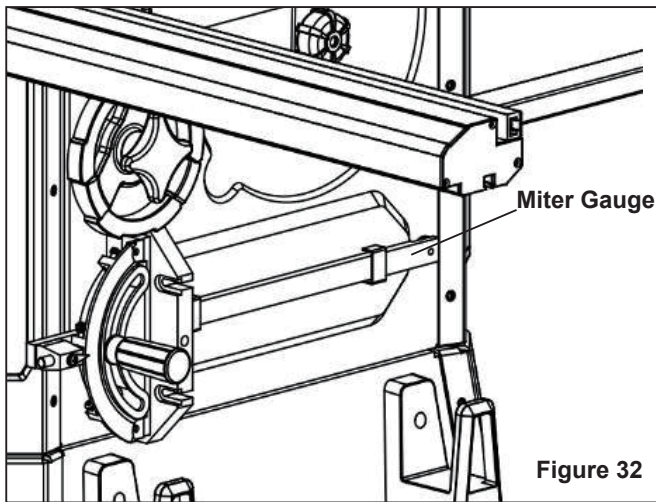

INSTALL RIP FENCE

Refer to Figure 34.

- Position rip fence assembly at end of saw. Be certain locking lever is in UP unlocked position.
- Place rip fence assembly onto rails, positioning clamp over rear rail and then placing rip fence onto front guide rail.
- Rip fence should now ride freely on rip fence rails. Once rip fence is completely installed, it should be parallel with the miter gauge and perpendicular to the table. If not, refer to "Rip Fence Adjustment" found on pages 16 and 17 in the Operation section of this manual.

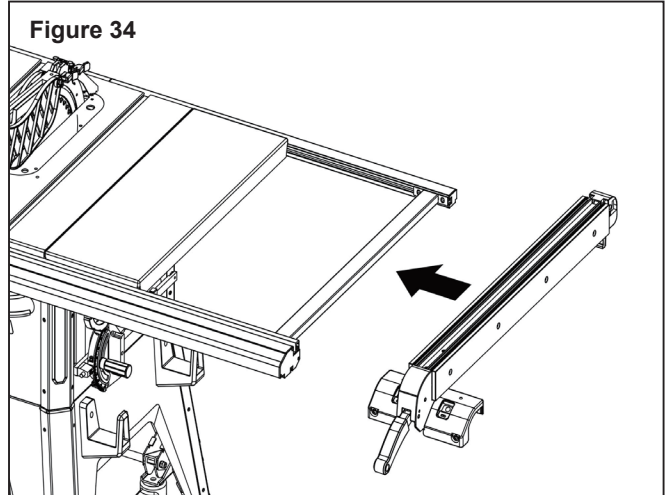

INSTALLATION

GROUNDING INSTRUCTIONS

WARNING: Improper connection of equipment grounding conductor can result in the risk of electrical shock. Equipment should be grounded while in use to protect operator from electrical shock.

- Check with a qualified electrician if grounding instructions are not understood or if in doubt as to whether the tool is properly grounded.
- This tool is equipped with an approved 3-conductor cord rated at 300V and a 3-prong grounding type plug (see Figure 35) for your protection against shock hazards.
- Grounding plug should be plugged directly into a properly installed and grounded 3-prong grounding-type receptacle, as shown (Figure 35).

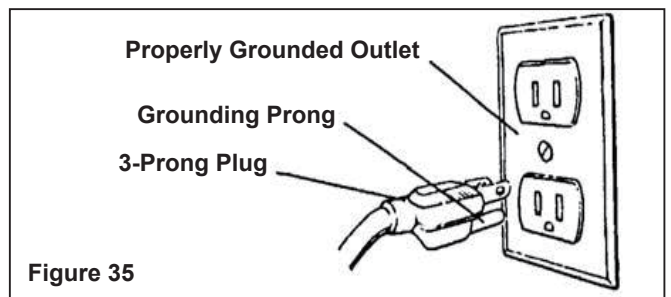

CONTINUED ON PAGE 14

- Do not remove or alter grounding prong in any manner. In the event of a malfunction or breakdown, grounding provides a path of least resistance for electrical shock.

WARNING: Do not permit fingers to touch the terminals of plug when installing or removing from outlet.

- Plug must be plugged into matching outlet that is properly installed and grounded in accordance with all local codes and ordinances. Do not modify plug provided. If it will not fit in outlet, have proper outlet installed by a qualified electrician.
- Inspect tool cords periodically and if damaged, have them repaired by an authorized service facility.
- Green (or green and yellow) conductor in cord is the grounding wire. If repair or replacement of the electric cord or plug is necessary, do not connect the green (or green and yellow) wire to a live terminal.
- Where a 2-prong wall receptacle is encountered, it must be replaced with a properly grounded 3-prong receptacle installed in accordance with National Electric Code and local codes and ordinances.

WARNING: This work should be performed by a qualified electrician.

A temporary 3-prong to 2-prong grounding adapter (see Figure 36) is available for connecting plugs to a two pole outlet if it is properly grounded.

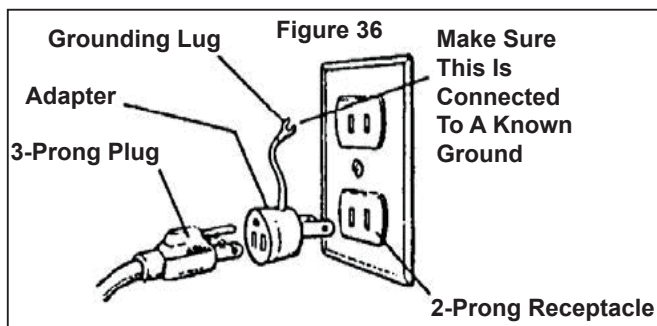

- Do not use a 3-prong to 2-prong grounding adapter unless permitted by local and national codes and ordinances.
- (A 3-prong to 2-prong grounding adapter is not permitted in Canada.) Where permitted, the rigid green tab or terminal on the side of the adapter must be securely connected to a permanent electrical ground such as a properly grounded water pipe, a properly grounded outlet box or a properly grounded wire system.
- Many cover plate screws, water pipes and outlet boxes are not properly grounded. To ensure proper ground, grounding means must be tested by a qualified electrician.

EXTENSION CORDS

- The use of any extension cord will cause some drop in voltage and loss of power.
- Wires of the extension cord must be of sufficient size to carry the current and maintain adequate voltage.
- Use the table to determine the minimum wire size (A.W.G.) extension cord.
- Use only 3-wire extension cords having 3-prong grounding type plugs and 3-pole receptacles which accept the tool plug.
- If the extension cord is worn, cut, or damaged in any way, replace it immediately.

Extension Cord Length (120V Operation)

	Wire Size A.W.G.
Up to 25 ft.	14
Up to 50 ft.	12

NOTE: Using extension cords over 50 ft. long is not recommended.

ELECTRICAL CONNECTIONS

WARNING: Make sure unit is off and disconnected from power source before inspecting any wiring.

The saw is prewired for use on a 120 volt, 60Hz power supply.

The power lines are inserted directly onto the switch. The green ground line must remain securely fastened to the frame to properly protect against electrical shock.

240 VOLT OPERATION

- To use the saw with a 240V, single-phase power supply, have a qualified electrician attach a 240 volt, 15A 3-prong (NEMA 6-15P) plug onto saw line cord and install the proper connectors and receptacles to power supply.
- See wiring diagram (Figure 37) for wiring instructions.

Figure 37

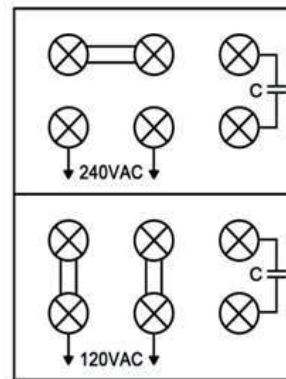

Wiring Schematic

OPERATION

DESCRIPTION

The RIKON 10" Contractor Saw, Model Number 10-205, offers precise cutting performance for all woods up to 3-1/8" thick. The saw is designed for the professional user and is ruggedly constructed for continuous service. The 10" Saw is recommended for use with a 10" blade.

The saw features an extra large cast iron table. Saw body has on board storage for push stick, miter gauge, rip fence and saw blades. Saw is equipped with a riving knife and a clear acrylic blade guard with anti-kickback feature. Cabinet is constructed of heavy gauge welded steel, totally enclosed and is ported for a 4" vacuum hose.

Rip Fence Assembly features a heavy-duty precision rip fence that is designed for simple and one-hand maneuverability.

Front rail is calibrated in inches and millimeters with a magnified window for close tolerances.

SPECIFICATIONS

Capacity with 10" Blade:

Depth of cut at 90°.....	3-1/8"
Maximum tilt angle of arbor (left).....	45°
Depth of cut at 45°.....	2-3/16"
Max. cut right of blade with rip fence.....	29-1/2"
Max. cut left of blade with rip fence.....	14-1/2"

Saw Dimensions:

Table height.....	37-3/8"
Cabinet depth.....	21-3/4"
Cabinet width.....	19"
Table area.....	27" x 40"
Front of table to blade.....	11-3/8"

Rip Fence Dimensions:

Rip fence.....	31-5/8"
Rip fence rails (front and rear).....	56-1/2"
Blade capacity maximum.....	10"
Blade arbor.....	5/8"
Dado blade capacity maximum.....	3/4"

Saw Construction:

Cabinet.....	Totally Enclosed Steel Panel
Table.....	Cast Iron
Rip fence.....	Aluminum Tube with HDPE Guide Plate
Drive system.....	V-belt
Exhaust port.....	4"
Miter gauge.....	Cast Aluminum with T-slot Roller Guide
Blade guard.....	Acrylic with Anti-kickback Pawls
Switch.....	Locking Paddle Switch with Overload
Arbor RPM.....	3450 RPM approx.
Motor:.....	1-3/4 HP, 3450 RPM, 120V/15A, 240V/7.5A Single-Phase, Capacitor Start/Run
Assembled weight.....	260 lbs

STARTING AND STOPPING THE SAW

Refer to figure 38.

WARNING: Never operate saw without blade guards in place. Be sure blade is not in contact with workpiece when motor is started. Start motor and allow saw to come to full speed.

WARNING: Make sure the electrical characteristics of motor nameplate and power source are the same.

- The ON/OFF switch is located under the front rail of the table saw at the left side.
- To turn saw on, stand to either side of the blade—never inline with it. Raise large red OFF paddle and pull up ON/OFF switch. Always allow saw blade to come up to full speed before cutting.
- Do not turn motor switch ON and OFF rapidly. This action overheats the motor and may cause saw blade to loosen.
- Never leave saw unattended while the power is on.
- To turn the table saw off, press the large red OFF paddle. Never leave saw unattended until the blade has come to a complete stop.

The saw can be locked from unauthorized use by locking the switch. To lock the switch:

- Turn the switch to OFF position and disconnect saw from power source.
- Pull the key out. The switch cannot be turned on with the key removed.

NOTE: Should the key be removed from the switch at the ON position, the switch can be turned off but cannot be turned on again.

- To replace key, slide key into the slot on switch until it snaps.

WARNING: For your own safety, lower blade or cutting tool below table surface. If blade is tilted, return it to vertical position. Turn off safety disconnect or circuit breaker when saw is not in use.

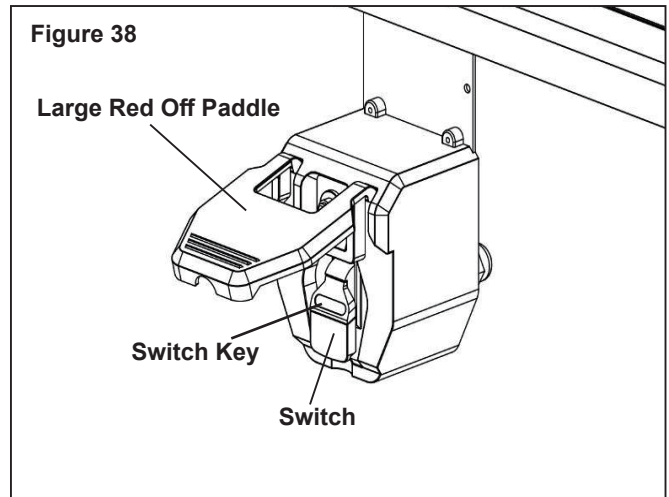

BLADE HEIGHT ADJUSTMENT

Refer to figure 39.

- Blade height is controlled by handwheel on the front of the saw.
- To adjust height, loosen locking hand knob. Rotate knob counterclockwise approximately three turns. Turn hand wheel to desired blade height.

CAUTION: For safety, blade should be raised only 1/8" above the surface of the material to be cut. However, if hollow ground blades are used, raise blade to its maximum height to allow for greater blade clearance.

- Lock blade height into position. Lock handwheel by tightening locking knob clockwise. Tighten only until snug.

IMPORTANT: Do not over tighten. Only a small amount of pressure is necessary to lock handwheel securely.

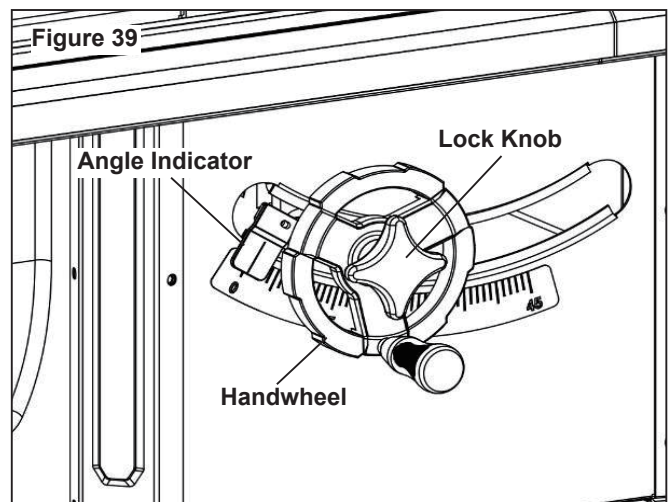

**BLADE HEIGHT ADJUSTMENT
CONTINUED ON PAGE 16**

BLADE TILT ADJUSTMENT

Refer to Figures 39 and 40.

- The saw blade can be set at any angle between 90° and 45°. Blade tilt is controlled by the handwheel (Fig. 40) on the right side of the saw. The indicator (Fig. 39, pg. 15) on front of saw shows the tilt angle of the blade.
- To adjust tilt, loosen locking hand knob. Rotate knob counterclockwise at least three turns. Turn handwheel to desired blade angle. Lock blade angle into position.
- Lock handwheel by tightening locking hand knob clockwise. Tighten only until snug.
- The saw is equipped with positive stops at 90° and 45°. These positive stops allow operator to position saw blade at 90° and 45° quickly and accurately.

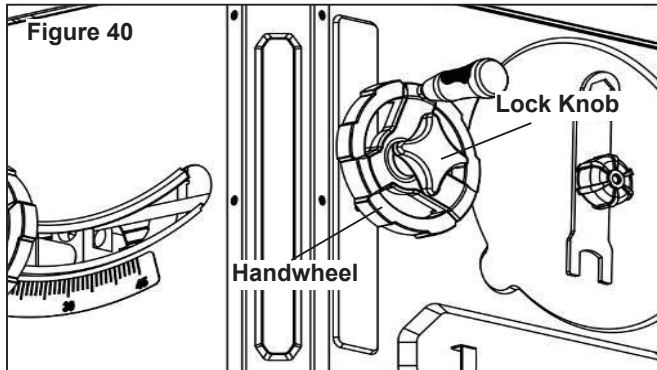

90° STOP ADJUSTMENT

Refer to Figures 39 thru 41.

- Raise saw blade above table as far as possible. Set blade at 90° to table by turning the tilting handwheel. Place a square on table and check to see if blade is perpendicular to the table. When checking put square flush against saw blade. Do not put square on teeth of saw blade.
- If the blade will not tilt to 90°, turn (counterclockwise) the set screw at the left front of the table insert until the blade can be positioned to 90°.
- Once the blade has been tilted to 90° (confirm this using your square), tighten the bevel handwheel lock knob, located on the side of the cabinet. This will keep the blade from tilting further.
- Turn the set screw (clockwise) until it comes in contact with the positive stop.
- Check tilt indicator pointer. If necessary, adjust pointer so it points to 0° mark on scale. To adjust pointer, remove handwheel and loosen screw on pointer. Be sure to tighten screw securely after adjustment is completed.

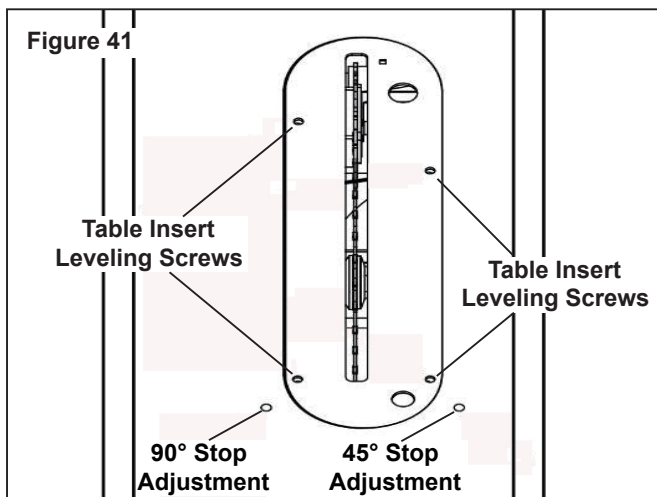

45° STOP ADJUSTMENT

Refer to Figures 39 thru 41.

- Tilt the saw blade to 45°. Using a combination square, check to see if blade is 45° to the table.
- If the blade will not tilt to 45°, turn (counterclockwise) the set screw located at the right of the table insert, until the blade can be positioned to 45°.
- With the blade at 45°, tighten the bevel handwheel lock knob to keep the blade from further tilting.
- Turn the set screw clockwise until it comes in contact with the positive stop.

TABLE INSERT ADJUSTMENT

Refer to Figure 41.

- The table insert must always be level with the saw table.
- Place a straight edge across the front and rear of the table insert. Check that the insert is perfectly level with the saw table.
- To level the table insert, turn one or more adjusting set screws as needed and recheck.
- The table insert is equipped with two finger holes for easy removal.

RIP FENCE ADJUSTMENT

The saw's rip fence is precision manufactured, incorporating fine adjustments for accurate cuts. The saw is built to allow the operator to accurately adjust the rip fence without problems in a matter of seconds.

LEVELING THE FENCE TO THE TABLE

- Lift the lock handle to unlock the fence.
- Observe the space between the fence bottom and the table. The space should be equal along the entire length of the fence.
- If the space is not equal, the rails need to be adjusted so that rails are at the same vertical position with respect to the table. See Rail Assembly, pages 10-11.

SETTING FENCE CLAMPING PRESSURE

Refer to Figure 42.

The rip fence has been adjusted at the factory to lock securely when the lock handle is pushed down. To adjust:

- Unlock fence and remove it from the rails.
- Adjust the hex nut until the fence is held securely when the lock handle is pushed down.

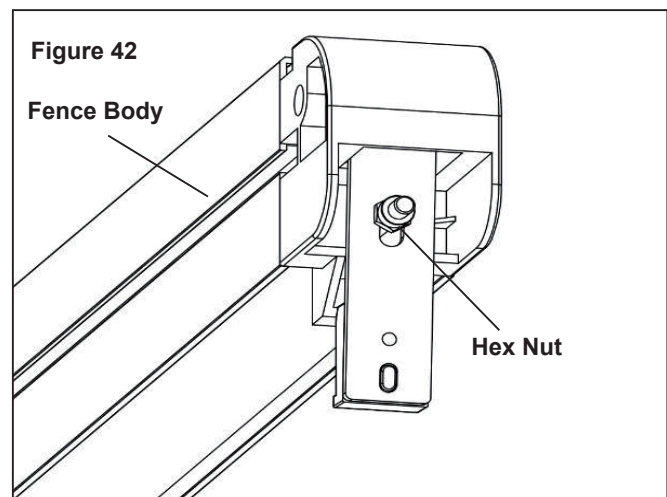

SETTING FENCE PERPENDICULAR AND PARALLEL

Refer to Figure 43.

PERPENDICULAR ADJUSTMENT

- Position fence anywhere on table and lock it down.
- Place a square on the table next to the fence and check to see that the fence is at 90° to the table.

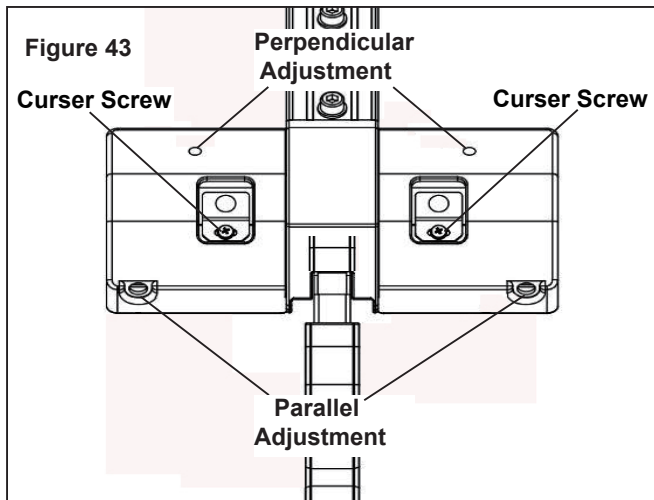

PARALLEL ADJUSTMENT

- Position fence so that fence edge is aligned with slot edge.
- Slot and fence edge should be parallel.
- If an adjustment is necessary, unlock the fence and turn either of the two adjusting screws.
- Lock fence in position and recheck. Continue this procedure until fence is square to the table.

CURSOR ADJUSTMENT

Refer to Figure 43.

- Raise the saw blade above the table.
- Position the fence several inches to the right of the saw blade.
- Lock the fence down and measure the exact distance between the saw blade and the inside of the fence.
- Loosen the screw on the right lens and slide it left or right until the cursor (red line) equals the measurement obtained in the previous step.
- Retighten the screws and make a test cut. Measure the cut piece to verify that the cursor is correctly set.
- Affix the rip fence several inches to the left of the saw blade and perform the procedure described above for the left lens.

NOTE: This adjustment should be checked whenever a new blade is installed.

RIP FENCE OPERATION

Refer to Figure 44.

- Unlock the fence by lifting the locking lever. Using the scale for placement, position the rip fence. Lock the rip fence into position by placing the locking lever in the down position.
- The rip fence is used for the following operations: ripping, bevel ripping, ploughing, resawing, rabbeting and dadoing.

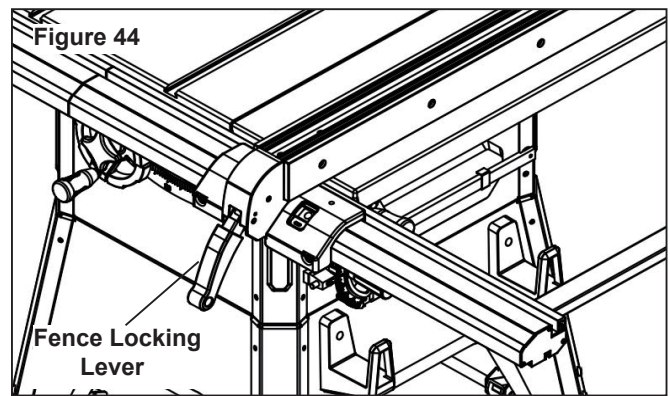

MITER GAUGE ADJUSTMENT

Refer to Figure 45.

- Miter gauge supplied with saw is equipped with individually adjustable index stops at 0° and 45°, right and left, and can be manually adjusted up to 60° right and left. Adjustment to index stops can be made by loosening the desired locking nut and tightening or loosening three adjusting screws. Be sure to tighten locking nut after adjustment is made.
- Face of the miter gauge has two holes for the purpose of attaching an auxiliary fence.
- Miter gauge is accurately constructed for precision work and is guided through the T-slot with a roller guide mounted at front of guide bar. Roller guide adds to miter gauge's stability and prevents the guide bar from leaving the T-slot.
- To operate the miter gauge, simply loosen locking handle and move the miter gauge body to the desired angle. The miter gauge will stop at 0° and 45°, both right and left. To position miter gauge body past these points, simply pull out gauge stop.
- Position the miter gauge body at desired angle and tighten the locking handle.
- Ensure the workpiece is straight and tight against miter gauge body so that the workpiece does not rock or rotate. Always use both hands when operating the miter gauge.
- The miter gauge is used for cross-cutting, compound miter cutting, miter cutting, rabbeting, bevel cutting and dadoing.

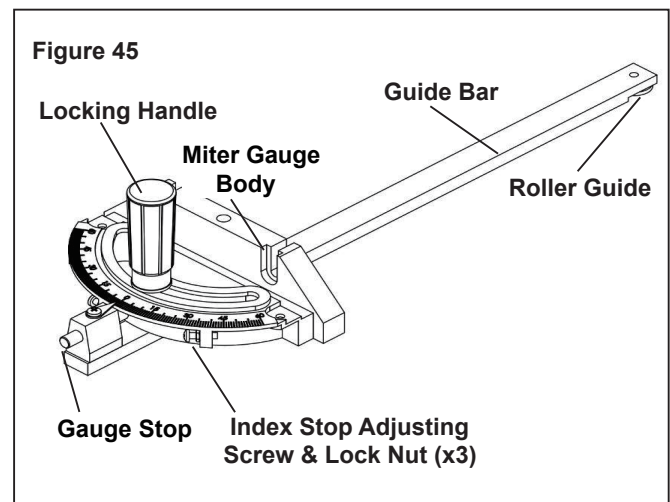

INSTALLING AND REMOVING THE RIVING KNIFE

Refer to Figure 46. Additional instructions on page 12.

Install:

- Line up the riving knife in the proper direction to the mounting bracket.
- Push the riving knife all the way down into the mounting bracket. Make sure the lock pin is locked in the hole of the riving knife. (The lock hole is on the button side of the riving knife).
- If the riving knife is not locked properly, hold the locking knob and pull the lock pin out; then re-insert the pin securely in the hole of the riving knife. While raising or lowering the knife, pin will snap in the hole of the knife when located at one of the three positions.
- Tighten the locking knob.

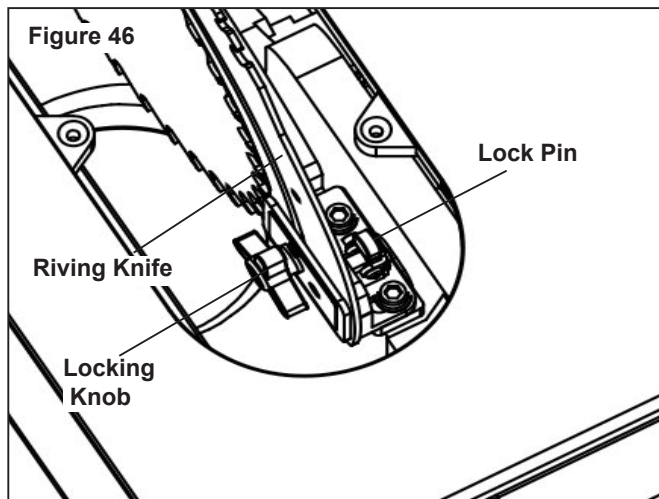

Remove:

- Loosen the locking knob.
 - Hold the knob and pull the locking pin out.
 - Remove the riving knife out of the mounting bracket.
- NOTE:** Make sure blade is at the highest position before adding or removing the riving knife.

CHANGING THE SAW BLADE

Refer to Figure 47.

WARNING: Turn the power switch “OFF” and unplug the power cord from its power source when changing the saw blade.

WARNING: When replacing blades, check the thickness stamped onto the riving knife. You must select a blade with a kerf width larger than the thickness of the riving knife. Thinner blades may cause the workpiece to bind during cutting.

WARNING: USE ONLY 10” diameter blades with 58” arbor holes, rated at or higher than 3800 R.P.M.

- Remove blade guard assembly and pawl assembly.
- Remove the table insert.
- Unlock the raise/lower handwheel lock and raise saw blade to maximum height.
- Depress the arbor lock pin (see Figure 47) and slowly rotate blade toward you until pin engages into arbor. Hold arbor in locked position.

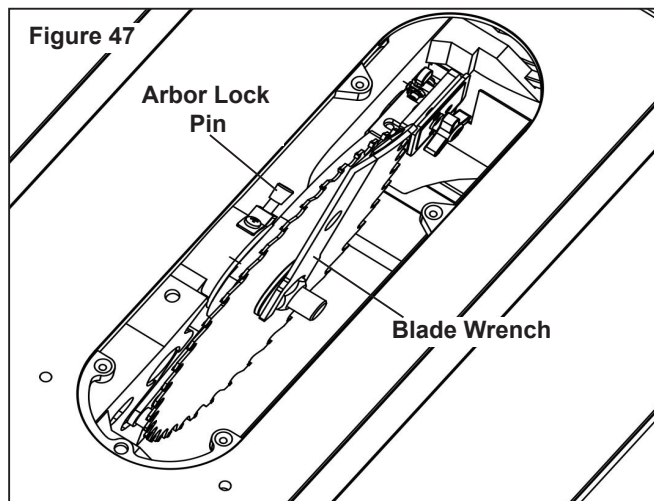

- Place supplied open-end wrench on the arbor nut. Turn wrench counterclockwise to loosen nut. Remove arbor nut, blade flange and saw blade.
- Place new blade on arbor. Make sure saw blade teeth point down at the front side of saw table. Place flange and nut on arbor and securely snug blade in position.
- Replace table insert.
- Replace blade guard assembly and pawl assembly.

TYPES OF SAWING OPERATIONS

WARNING: For your own safety, always observe the following safety precautions.

- Never make any cut freehand (without using miter gauge or rip fence). Blade can bind in the cut and cause a kick back.
 - Always lock miter gauge or rip fence securely when in use.
 - Remove rip fence from the table when miter gauge is in use.
 - Remove miter gauge from table when rip fence is in use.
 - Make sure blade guard is installed for all “through sawing” operations. Through sawing operations are those operations in which the saw blade cuts completely through the thickness of the wood. Replace guard immediately after completion of resawing, rabbeting and dadoing.
- Frequently check action of anti-kickback pawls by passing the workpiece alongside the spreader while saw is off. Pull the workpiece toward you. If the pawls do not dig into the workpiece and hold it, the pawls must be sharpened. (See Maintenance section, page 20.)
- Have blade extend approximately 1/8” above top of work piece. Additional blade exposure increases hazard potential.
 - Do not stand directly in front of blade in case of a kickback. Stand to either side of the blade.
 - Keep your hands clear of the blade and out of the path of the blade.
 - If the blade stalls or stops while cutting, turn switch OFF and safety disconnect OFF before attempting to free the blade.
 - Do not reach over or behind the blade to pull the workpiece through the cut, to support long or heavy workpieces, to remove small cut-off pieces of material or for any other reason.

- Do not pick up small pieces of cut-off material from the table. Remove them by pushing them off table with a long stick. Otherwise they could be thrown back at you by the rear of the blade.
- Do not remove small pieces of cut-off material that may become trapped inside blade guard while saw is on. This could endanger your hands or cause a kickback. Turn saw off. After blade has stopped turning, lift guard and remove the piece.
- Always lower blade below the table level when machine is not in use.

CROSSCUTTING

WARNING: Use caution when starting the cut to prevent binding of the guard against the workpiece.

This cut is performed with the miter gauge set at "0", and is used for cutting across the workpiece grain at 90° (blade square with both the edge and flat side of wood).

MITER CUTTING

WARNING: Miter angles greater than 45° may force the blade guard assembly into the saw blade causing damage to the blade guard assembly and personal injury. Before starting the motor, test the operation by feeding the workpiece into the blade guard assembly. If the blade guard assembly contacts the blade, place the workpiece under the blade guard assembly, not touching the blade, before starting the motor.

WARNING: Certain workpiece shapes, such as molding may not lift the blade guard assembly properly. With the power off, feed the workpiece slowly into the blade guard area and until the workpiece touches the blade. If the blade guard assembly contacts the blade, place the workpiece under the blade guard assembly, not touching the blade, before starting the motor. This cut is performed with the miter gauge, and is used for cutting at an angle other than 90° square with the edge of the workpiece.

BEVEL CROSSCUTTING

WARNING: When possible, use the right miter gauge slot when bevel crosscutting so that the blade tilts away from the miter gauge and your hands.

WARNING: Use caution when starting the cut to prevent binding of the guard against the workpiece.

This cut is performed with the miter gauge, and is the same as crosscutting, except that the workpiece is also cut at an angle other than 90° square to the flat side of the wood (blade is at an angle).

COMPOUND MITER CUTTING

This cut is performed with the miter gauge, and is a combination of miter cutting and bevel crosscutting. The cut is made at an angle other than 90° to both the edge and flat side of wood.

RIPPING

WARNING: When bevel ripping and whenever possible, place the fence on the side of the blade so that the blade is tilted away from the fence and hands. Keep hands clear of the blade and use a push stick to feed the workpiece if there is less than 6" between the fence and the blade.

This cut is performed with the rip fence, and is used to cut the workpiece lengthwise with the grain. Position the fence to the desired width of rip and lock in place. When ripping long boards or large panels, always use a work support.

BEVEL RIPPING

WARNING: Before connecting the table saw to the power source or operating the saw, always inspect the blade guard assembly and riving knife for proper alignment and clearance with saw blade. Check alignment after each change of bevel angle.

WARNING: When possible, place the fence on the right side of the blade so that the blade is tilted away from the fence and hands. Keep your hands clear of the blade and use a pushstick to feed the workpiece if there is less than 6" between the fence and the blade.

This cut is performed with the rip fence, and is the same as ripping, except that the blade is set at an angle other than 90°.

RESAWING

This cut is performed with the rip fence, and is used to rip a workpiece through its thickness rather than across its flat width. Do not attempt to resaw bowed or warped material.

NOTE: It may be necessary to remove blade guard and use work supports as well as push blocks when performing this operation.

WARNING: Install blade guard immediately upon completion of resawing operation.

PLOUGHING

This cut is performed with the rip fence, and is used to make a groove lengthwise with the grain of the workpiece. Use proper hold downs and feed devices.

RABBETING

This cut is performed with either the miter gauge or rip fence. Rabbeting is used to cut out a section of the corner of a workpiece, across an end or along an edge. To make a rabbet requires cuts which do not go all the way through the material.

Therefore, blade guard must be removed. Install blade guard immediately upon completion of rabbeting operation. Rabbet cuts can also be made using dado head.

DADOING

This cut is performed with either the miter gauge or rip fence. Dadoing is done with a set of blades (dado set) rather than standard saw blades. The dado set is used to groove wood similar to ploughing and rabbeting. However, the dado set allows operator to remove more material in one pass. The operator, with a dado set, can vary width of cut up to 3/4".

Instructions for operating dado set are contained in owner's manual furnished with dado set. Dadoing requires cuts which do not go all the way through material. Therefore, blade guard must be removed. Dado sets have different characteristics than saw blades.

When using a dado set, the following parts must be substituted dado table insert (not included).

IMPORTANT: Always use correct insert. When using the dado set, use caution. Use featherboards and push sticks as applicable.

WARNING: Always immediately replace the standard blade, blade guard and blade insert when you are finished dadoing.

FREEHAND

WARNING: Freehand is a very dangerous operation of making a cut without using the miter gauge or rip fence. Freehand cuts **must never be performed** on a Table Saw.

CUTTING OVERSIZED WORKPIECES

When cutting long workpieces or large panels, always support workpiece that is not on table. Use adjustable roller stand or make simple support by clamping a piece of plywood to saw horse. Add facings to miter gauge or rip fence as needed.

IMPORTANT: Do not allow facings to interfere with operation of blade guard.

DUST COLLECTING

- Saw is equipped with a 4" male exhaust port.
- Before starting saw, see that all adjustments are properly made and guards in place. With power disconnected, turn pulley by hand to make sure everything is correct before connecting power and starting saw.

BLADE SELECTION

Blade selection is based on type of material being cut and how it will be cut. There are three general types of saw blades: rip saw blades cut with grain of wood, cut-off saw blades cut across grain, and combination saw blades cut with grain, across grain and any angle to grain.

Blades vary in many aspects. When selecting a blade, the following blade characteristics should match up with operation to be performed and type of material to be cut: type of steel; quality of steel; tooth style; tooth set; carbide tipped; grind; number of teeth and size.

IMPORTANT: Your saw is only as accurate and efficient as blade or cutting tool used.

First, be certain to use the appropriate type of cutting tool for the operation to be performed. Second, it is strongly recommended that high-quality blades and cutting tools be used. Be certain blades and cutting tools are kept sharp and in good working order. Check blades periodically and replace or sharpen if necessary.

MAINTENANCE

WARNING: Do not attempt under any circumstances, to service, repair, dismantle, or disassemble any mechanical or electrical components without physically disconnecting all power sources.

CLEANING

- Clean off any preservative on bright (machined) parts with appropriate solvent (mineral spirits). Avoid getting cleaning fluid on any rubber parts as they tend to deteriorate rubber.
- Use soap and soft water on rubber and plastic parts.
- After cleaning, lubricate unpainted surfaces with a light application of medium consistency machine oil. This lubrication should be repeated at least once every six months.

NOTE: Instead of oil, a good quality paste wax can be applied to rip fence and table surface. Paste wax will enhance movement of workpieces. In addition to providing lubrication, paste wax will help prevent rusting.

- Keep your machine and your workshop clean. Do not allow sawdust to accumulate on saw or inside cabinet. Frequently vacuum or blow out any sawdust that may accumulate within cabinet.
- Be certain motor and internal mechanisms are clean and are frequently vacuumed or blown free of any dirt.

LUBRICATION

All bearings on the arbor are shielded ball bearings. These bearings are permanently lubricated at the factory.

- As needed, clean the grease off the rack and worm gears of height and tilt mechanism. Lubricate rack and gears with a medium viscosity machine oil.
- Be sure to lubricate trunnion ways and all bushings.
- Occasionally oil all other bearing points, including blade guard assembly, miter gauge and rip fence.

SERVICE

- Replace belts and worn parts as needed. If power cords are worn, cut, or damaged in any way, have them replaced immediately.
- Make sure teeth of anti-kickback pawls are always sharp.
- Sharpen dull teeth using a few light strokes of a smooth cut flat file.

TROUBLESHOOTING

SYMPTOM	POSSIBLE CAUSE(S)	CORRECTIVE ACTION
Saw stops or will not start	<ol style="list-style-type: none"> 1. Overload tripped 2. Saw unplugged from wall or motor 3. Fuse blown or circuit breaker tripped 4. Cord damaged 5. Defective capacitor 	<ol style="list-style-type: none"> 1. Allow motor to cool and reset by pushing reset switch 2. Check all plug connections 3. Replace fuse or reset circuit breaker 4. Replace cord 5. Replace capacitor
Excessive vibration	<ol style="list-style-type: none"> 1. Stand on uneven floor 2. Damaged saw blade 3. Bad drive V-belts 4. Bent pulley 5. Improper motor mounting 6. Loose hardware 7. Loose set screw in pulley 	<ol style="list-style-type: none"> 1. Reposition on flat, level surface 2. Replace saw blade 3. Replace drive V-belts 4. Replace pulley 5. Check and adjust motor 6. Tighten hardware 7. Tighten set screw
Cannot make square cut when crosscutting	Miter gauge not adjusted properly	Adjust miter gauge
Blade stalls (however, motor turns)	<ol style="list-style-type: none"> 1. Drive belts not tight 2. Drive belts worn 	<ol style="list-style-type: none"> 1. Adjust drive belt tension 2. Replace drive belts
Blade does not come up to speed	<ol style="list-style-type: none"> 1. Extension cord too light or too long 2. Low shop voltage 3. Motor not wired for correct voltage 	<ol style="list-style-type: none"> 1. Replace with adequate size cord 2. Contact your local electric company 3. Refer to motor junction box
Cut binds, burns or stalls when ripping	<ol style="list-style-type: none"> 1. Dull blade with improper tooth set 2. Blade is binding at one end of cut (heeling) 3. Warped board 4. Rip fence not parallel to blade 5. Riving knife out of alignment 6. Excessive feed rate 	<ol style="list-style-type: none"> 1. Sharpen or replace blade 2. Adjust table and rip fence parallel to blade 3. Make sure concave or hollow side is facing down; feed slowly 4. Adjust rip fence 5. Adjust riving knife to fall in line with blade 6. Reduce feed rate
Cut not true at 45 or 90° positions	Positive stops not properly adjusted	Adjust blade tilt
Tilt and elevating handwheel difficult to turn	<ol style="list-style-type: none"> 1. Sawdust on rack and worm gears 2. Bushings and bearing surfaces dirty 	<ol style="list-style-type: none"> 1. Clean and relubricate 2. Clean thoroughly and lubricate
Rip fence binds on guide tube	<ol style="list-style-type: none"> 1. Guide rails or extension wing not properly installed 2. Guide of rip fence not adjusted properly 	<ol style="list-style-type: none"> 1. Reassemble guide rails 2. Adjust guides
Frequent opening of fuses or circuit breakers	<ol style="list-style-type: none"> 1. Motor overloaded 2. Fuses or circuit breakers do not have sufficient capacity 	<ol style="list-style-type: none"> 1. Feed work slower into blade 2. Install proper size fuses or circuit breakers
Material kicked back from blade	<ol style="list-style-type: none"> 1. Rip fence out of alignment 2. Riving knife not aligned with blade 3. Feeding stock without rip fence 4. Riving knife not in place 5. Dull blade 6. Letting go of material before it is past blade 7. Anti-kickback fingers dull 	<ol style="list-style-type: none"> 1. Align rip fence with miter slot 2. Align riving knife with blade 3. Always use rip fence or miter gauge 4. Install riving knife 5. Replace blade 6. Push material all the way past blade before releasing work 7. Replace or sharpen anti-kickback fingers

PARTS DIAGRAM A

NOTE: Please reference the Manufacturer's Part Number when calling for Replacement Parts.

For Parts under Warranty, the Serial Number of your machine is required.

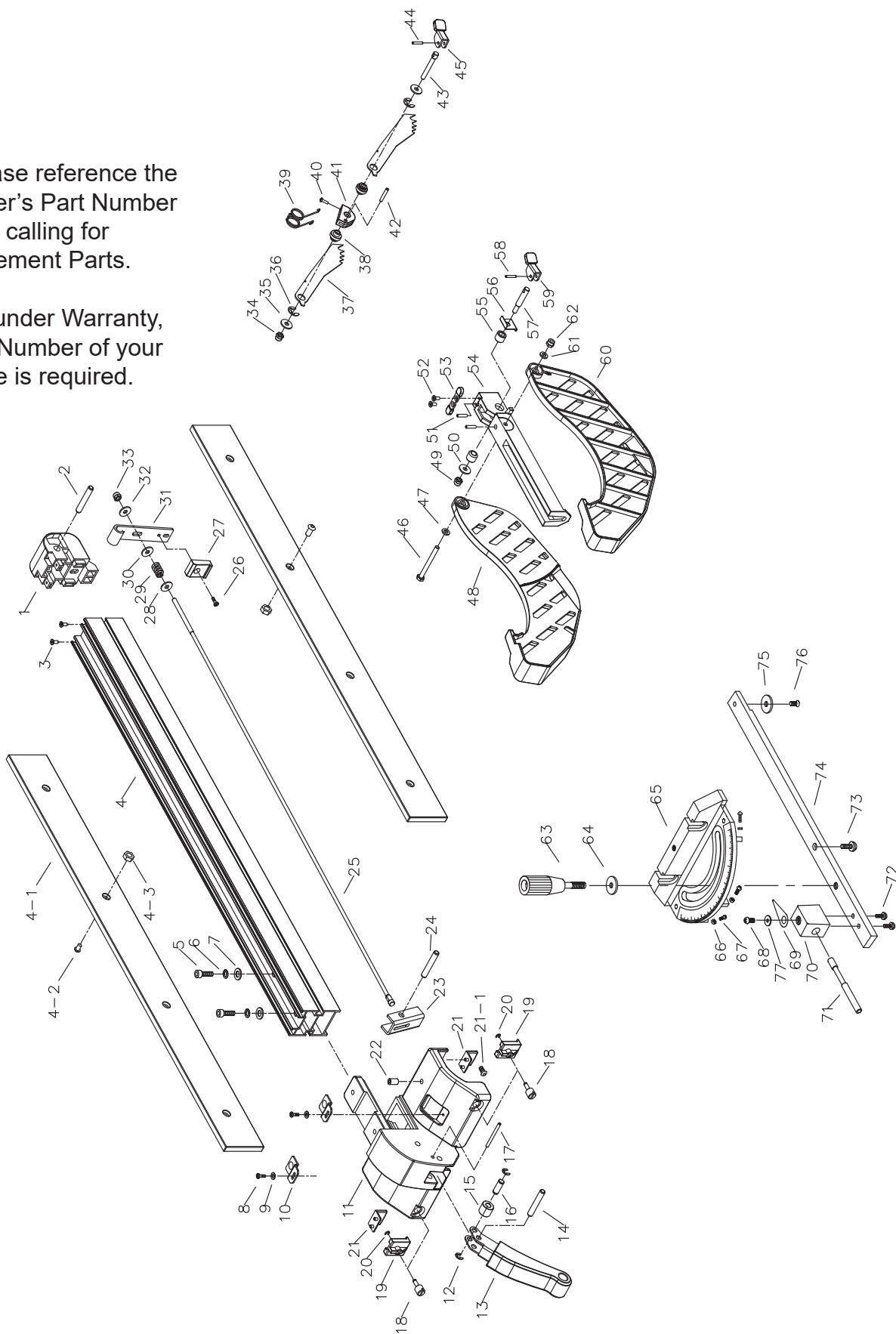

PARTS LIST A

KEY NO.	MFG. PART NO.	DESCRIPTION	KEY NO.	MFG. PART NO.	DESCRIPTION
1A	P10-205-1A	Fence rear support	37A	P10-205-37A	Kickback pawl
2A	P10-205-2A	10X50mm Spring pin	38A	P10-205-38A	Bushing
3A	P10-205-3A	3.5-1.3x13mm Thread forming screw	39A	P10-205-39A	Spring
4A	P10-205-4A	Fence	40A	P10-205-40A	3-0.5X10 Pan head screw
4.1A	P10-205-4.1A	Guide plate	41A	P10-205-41A	Support bracket
4.2A	P10-205-4.2A	6-1.0X12mm Socket pan head screw	42A	P10-205-42A	4X30mm Spring pin
4.3A	P10-205-4.3A	6-1.0mm Hex nut	43A	P10-205-43A	Pivot pin
5A	P10-205-5A	8-1.25X20mm Socket head bolt	44A	P10-205-44A	4X12mm Spring pin
6A	P10-205-6A	8mm Lock washer	45A	P10-205-45A	Latch
7A	P10-205-7A	8mm Flat washer	46A	P10-205-46A	6-1.0X60mm Hex head bolt
8A	P10-205-8A	4-0.7X10mm Pan head screw	47A	P10-205-47A	6mm Flat washer
9A	P10-205-9A	4mm Flat washer	48A	P10-205-48A	Left blade guard
10A	P10-205-10A	Pointer	49A	P10-205-49A	Lock nut
11A	P10-205-11A	Fence front support	50A	P10-205-50A	6mm Flat washer
12A	P10-205-12A	Retaining ring	51A	P10-205-51A	5-0.8X20mm Set screw
13A	P10-205-13A	Locking handle	52A	P10-205-52A	4-0.7X10mm Flat head screw
14A	P10-205-14A	8X50mm Spring pin	53A	P10-205-53A	Support plate
15A	P10-205-15A	Bushing	54A	P10-205-54A	Guard case
16A	P10-205-16A	Shaft	55A	P10-205-55A	Bushing
17A	P10-205-17A	5X50mm Spring pin	56A	P10-205-56A	Plate
18A	P10-205-18A	Adjusting screw	57A	P10-205-57A	Pivot pin
19A	P10-205-19A	Adjusting block	58A	P10-205-58A	4X12mm Spring pin
20A	P10-205-20A	Retaining ring	59A	P10-205-59A	Latch
21A	P10-205-21A	Sliding pad	60A	P10-205-60A	Right blade guard
21.1A	P10-205-21.1A	4-0.7X6mm Pan head screw	61A	P10-205-61A	6mm Flat washer
22A	P10-205-22A	Nylon screw	62A	P10-205-62A	Lock nut
23A	P10-205-23A	Front locking plate	63A	P10-205-63A	Knob
24A	P10-205-24A	8X50mm Spring pin	64A	P10-205-64A	8mm Flat washer
25A	P10-205-25A	Rod	65A	P10-205-65A	Miter gauge
26A	P10-205-26A	5-0.8X8mm Pan head screw	66A	P10-205-66A	4-0.7mm Hex nut
27A	P10-205-27A	Rear locking plate	67A	P10-205-67A	4-0.7X16mm Pan head screw
28A	P10-205-28A	6mm Flat washer	68A	P10-205-68A	4-0.7X10mm Pan head screw
29A	P10-205-29A	Spring	69A	P10-205-69A	Pointer
30A	P10-205-30A	6mm Flat washer	70A	P10-205-70A	Block
31A	P10-205-31A	Clamp	71A	P10-205-71A	Pin
32A	P10-205-32A	6mm Flat washer	72A	P10-205-72A	4-0.7X12mm Pan head screw
33A	P10-205-33A	Lock nut	73A	P10-205-73A	Screw
34A	P10-205-34A	Lock nut	74A	P10-205-74A	Bar
35A	P10-205-35A	Flat washer	75A	P10-205-75A	Washer
36A	P10-205-36A	Retaining ring	76A	P10-205-76A	6-1.0X8mm Flat head screw
			77A	P10-205-77A	4mm Flat washer

NOTE: Please reference the Manufacturer's Part Number when calling for Replacement Parts.
For Parts under Warranty, the Serial Number of your machine is required.

PARTS DIAGRAM B

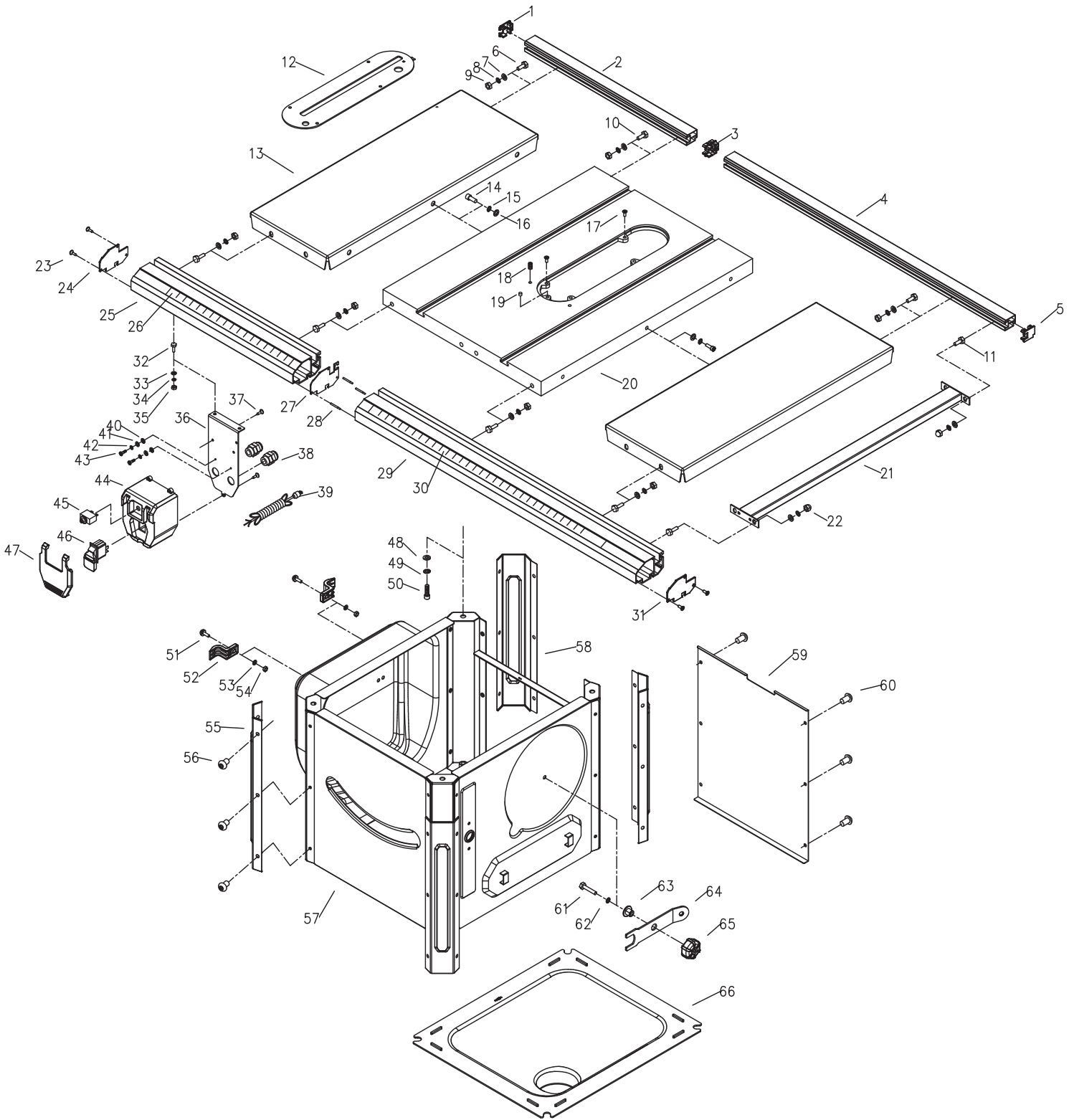

NOTE: Please reference the Manufacturer's Part Number when calling for Replacement Parts. For Parts under Warranty, the Serial Number of your machine is required.

PARTS LIST B

KEY NO.	MFG. PART NO.	DESCRIPTION	KEY NO.	MFG. PART NO.	DESCRIPTION
1B	P10-205-1B	Left rear rail cap	34B	P10-205-34B	6mm Lock washer
2B	P10-205-2B	Left rear rail	35B	P10-205-35B	6-1.0mm Hex nut
3B	P10-205-3B	Rear rail connector	36B	P10-205-36B	Switch mounting plate
4B	P10-205-4B	Right rear rail	37B	P10-205-37B	3.5-1.3x9.5mm Thread forming screw
5B	P10-205-5B	Right rear rail cap	38B	P10-205-38B	Strain relief
6B	P10-205-6B	8-1.25X30mm Hex head bolt	39B	P10-205-39B	Power cord
7B	P10-205-7B	8mm Flat washer	40B	P10-205-40B	4mm Serrated washer
8B	P10-205-8B	8mm Lock washer	41B	P10-205-41B	4mm Flat washer
9B	P10-205-9B	8-1.25mm Hex nut	42B	P10-205-42B	4mm Lock washer
10B	P10-205-10B	8-1.25X30mm Hex head bolt	43B	P10-205-43B	4-0.7X8mm Pan head screw
11B	P10-205-11B	8-1.25X16mm Socket head bolt	44B	P10-205-44B	Switch box
12B	P10-205-12B	Table insert	45B	P10-205-45B	Circuit breaker
13B	P10-205-13B	Table extension	46B	P10-205-46B	Switch
14B	P10-205-14B	10-1.5X25mm Socket head bolt	47B	P10-205-47B	Paddle
15B	P10-205-15B	10mm Lock washer	48B	P10-205-48B	8mm Flat washer
16B	P10-205-16B	10mm Flat washer	49B	P10-205-49B	8mm Lock washer
17B	P10-205-17B	5-0.8X16mm Flat head screw	50B	P10-205-50B	8-1.25X20mm Socket head bolt
18B	P10-205-18B	8-1.25X16mm Set screw	51B	P10-205-51B	6-1.0X20mm Socket pan head screw
19B	P10-205-19B	Magnet	52B	P10-205-52B	Line cord hook
20B	P10-205-20B	Table	53B	P10-205-53B	6mm Flat washer
21B	P10-205-21B	Brace	54B	P10-205-54B	6-1.0mm Hex nut
22B	P10-205-22B	Lock nut	55B	P10-205-55B	Front corner cover
23B	P10-205-23B	3.5-1.3X13mm Thread forming screw	56B	P10-205-56B	6-1.0X12mm Socket pan head screw
24B	P10-205-24B	Left front rail cap	57B	P10-205-57B	Box base
25B	P10-205-25B	Left front rail	58B	P10-205-58B	Rear corner cover
26B	P10-205-26B	Left scale	59B	P10-205-59B	Rear panel
27B	P10-205-27B	Front partition	60B	P10-205-60B	6-1.0X12mm Socket pan head screw
28B	P10-205-28B	Connecting pin	61B	P10-205-61B	8-1.25X35mm Hex head bolt
29B	P10-205-29B	Right front rail	62B	P10-205-62B	8mm Lock washer
30B	P10-205-30B	Right scale	63B	P10-205-63B	Support block
31B	P10-205-31B	Right front rail cap	64B	P10-205-64B	Wrench
32B	P10-205-32B	6-1.0X16mm Hex head bolt	65B	P10-205-65B	Knob
33B	P10-205-33B	6mm Flat washer	66B	P10-205-66B	Dust chute

NOTE: Please reference the Manufacturer's Part Number when calling for Replacement Parts.
For Parts under Warranty, the Serial Number of your machine is required.

PARTS DIAGRAM C

NOTE: Please reference the Manufacturer's Part Number when calling for Replacement Parts.

For Parts under Warranty, the Serial Number of your machine is required.

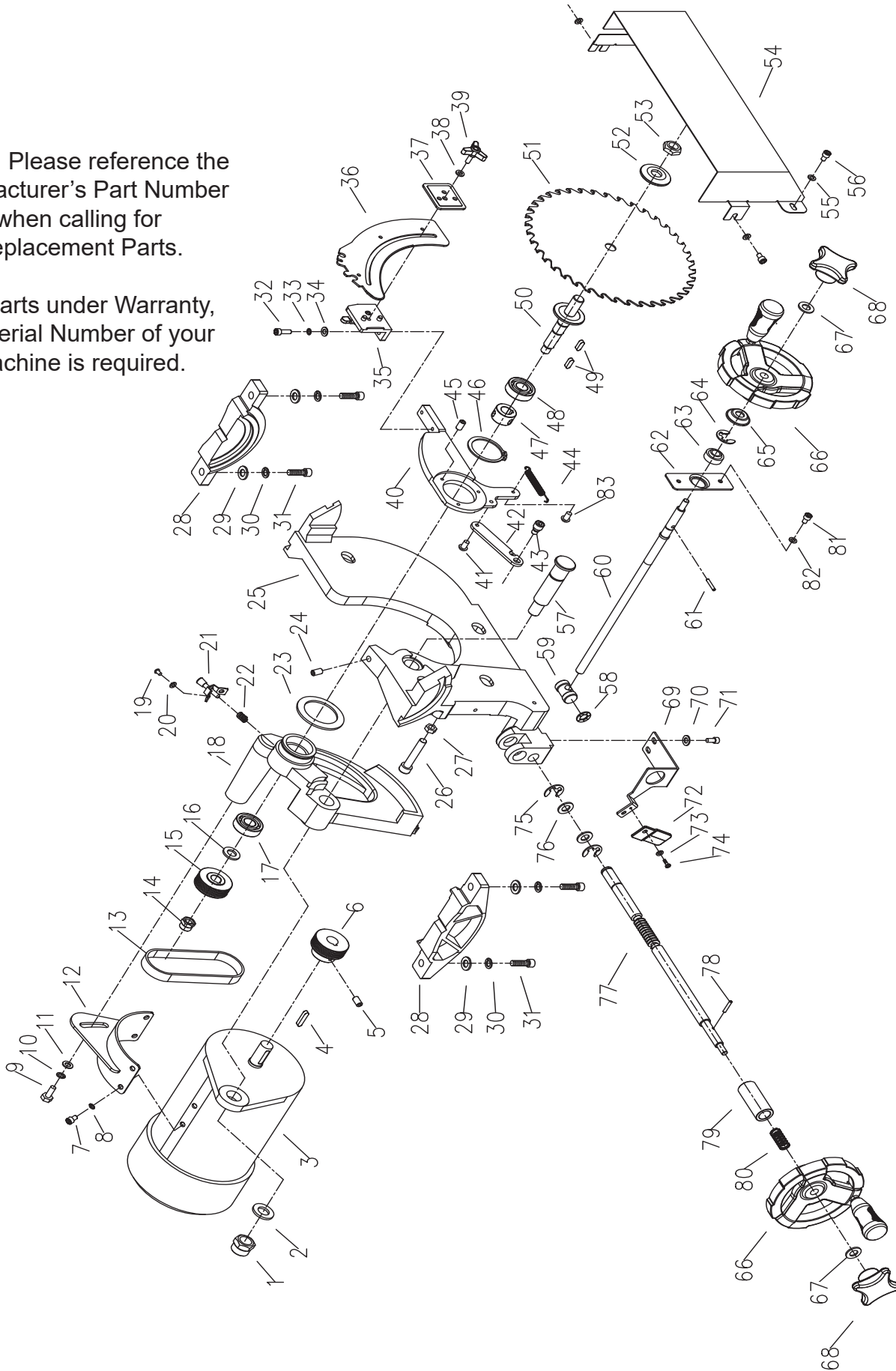

PARTS LIST C

KEY NO.	MFG. PART NO.	DESCRIPTION	KEY NO.	MFG. PART NO.	DESCRIPTION
1C	P10-205-1C	Lock nut	43C	P10-205-43C	Screw
2C	P10-205-2C	16mm Flat washer	44C	P10-205-44C	Spring
3C	P10-205-3C	Motor	45C	P10-205-45C	5-0.8X6mm Set screw
4C	P10-205-4C	5X5X30mm Key	46C	P10-205-46C	Retaining ring
5C	P10-205-5C	6-1.0X8mm Set screw	47C	P10-205-47C	Bushing
6C	P10-205-6C	Motor pulley	48C	P10-205-48C	6203ZZ Ball bearing
7C	P10-205-7C	6-1.0X10mm Socket head bolt	49C	P10-205-49C	Key
8C	P10-205-8C	6mm Flat washer	50C	P10-205-50C	Arbor
9C	P10-205-9C	8-1.25X16mm Hex head bolt	51C	P10-205-51C	Blade
10C	P10-205-10C	8mm Lock washer	52C	P10-205-52C	Flange
11C	P10-205-11C	8mm Flat washer	53C	P10-205-53C	Arbor nut
12C	P10-205-12C	Motor support bracket	54C	P10-205-54C	Lower blade guard
13C	P10-205-13C	Belt	55C	P10-205-55C	6mm Flat washer
14C	P10-205-14C	Lock nut	56C	P10-205-56C	6-1.0X10mm Socket head bolt
15C	P10-205-15C	Spindle pulley	57C	P10-205-57C	Shaft
16C	P10-205-16C	Spacer	58C	P10-205-58C	Lock washer
17C	P10-205-17C	620ZZ Ball bearing	59C	P10-205-59C	Bevel nut
18C	P10-205-18C	Blade and motor support case	60C	P10-205-60C	Bevel screw
19C	P10-205-19C	5-0.8X12mm Pan head screw	61C	P10-205-61C	3X20mm Spring pin
20C	P10-205-20C	5mm Flat washer	62C	P10-205-62C	Bearing fixing plate
21C	P10-205-21C	Blade locking assembly+E195	63C	P10-205-63C	Bearing
22C	P10-205-22C	Spring	64C	P10-205-64C	Retaining ring
23C	P10-205-23C	Spacer	65C	P10-205-65C	Bevel locking plate
24C	P10-205-24C	10-1.5x20mm Set screw	66C	P10-205-66C	Handwheel
25C	P10-205-25C	Main trunnion	67C	P10-205-67C	8mm Flat washer
26C	P10-205-26C	10-1.5X40mm Socket head bolt	68C	P10-205-68C	Lock nut
27C	P10-205-27C	10-1.5mm Hex nut	69C	P10-205-69C	Pointer support
28C	P10-205-28C	Trunnion	70C	P10-205-70C	6mm Flat washer
29C	P10-205-29C	10mm Flat washer	71C	P10-205-71C	6-1.0X10mm Socket head bolt
30C	P10-205-30C	10mm Lock washer	72C	P10-205-72C	Angle pointer
31C	P10-205-31C	10-1.5X30 Socket head bolt	73C	P10-205-73C	4mm Flat washer
32C	P10-205-32C	6-1.0X20mm Socket pan head screw	74C	P10-205-74C	4-0.7x8 Pan head screw
33C	P10-205-33C	6mm Lock washer	75C	P10-205-75C	Retaining ring
34C	P10-205-34C	6mm Flat washer	76C	P10-205-76C	16mm Flat washer
35C	P10-205-35C	Riving knife support assembly	77C	P10-205-77C	Elevation shaft
36C	P10-205-36C	Riving knife	78C	P10-205-78C	3X20mm Spring pin
37C	P10-205-37C	Clamp	79C	P10-205-79C	Bushing
38C	P10-205-38C	6mm Flat washer	80C	P10-205-80C	Spring
39C	P10-205-39C	Lock knob	81C	P10-205-81C	5-0.8X12mm Pan head screw
40C	P10-205-40C	Mounting plate	82C	P10-205-82C	5mm Flat washer
41C	P10-205-41C	Rivet	83C	P10-205-83C	5-0.8X8mm Socket head bolt
42C	P10-205-42C	Connecting plate			

NOTE: Please reference the Manufacturer's Part Number when calling for Replacement Parts.
For Parts under Warranty, the Serial Number of your machine is required.

PARTS DIAGRAM D

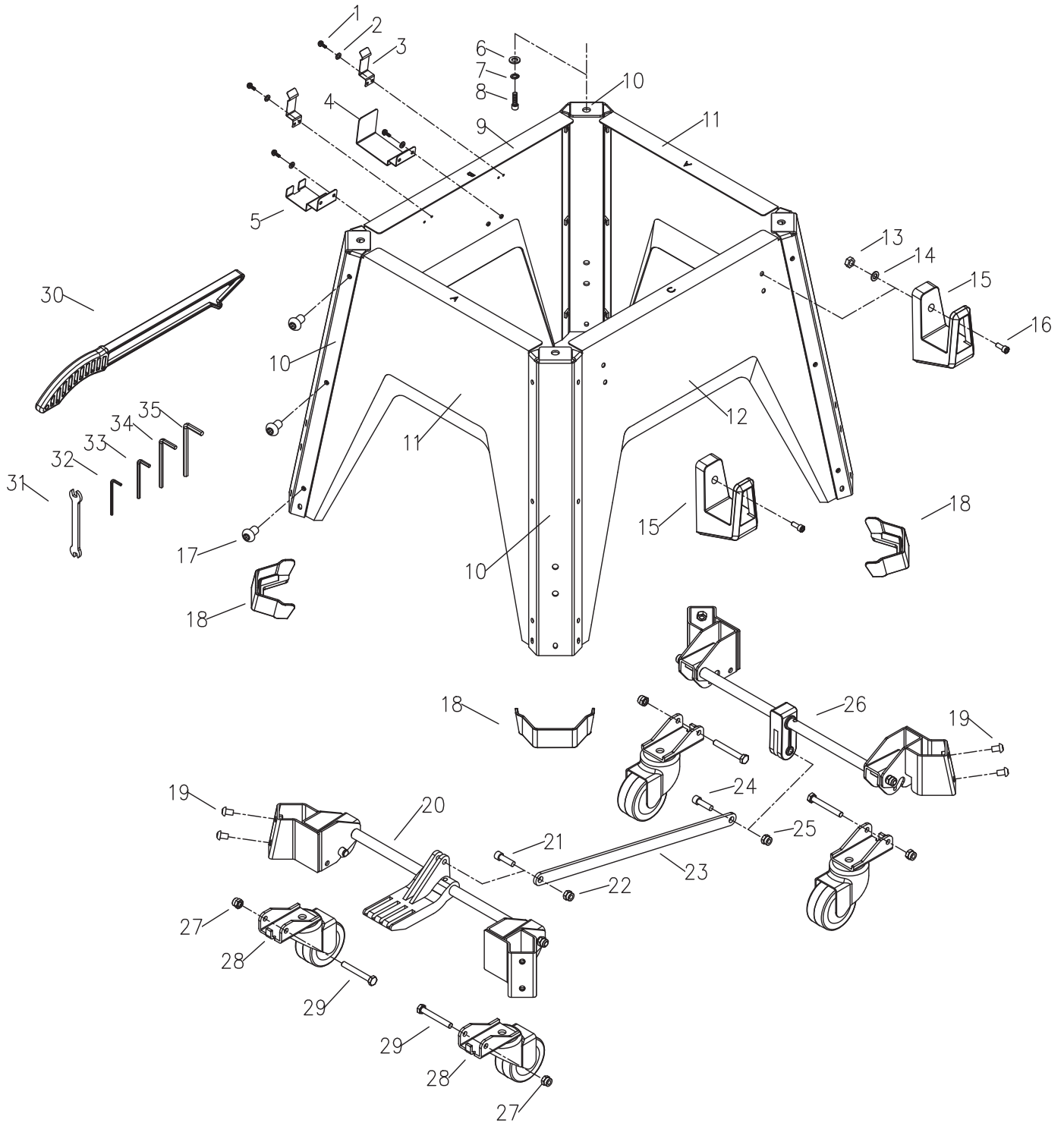

NOTE: Please reference the Manufacturer's Part Number when calling for Replacement Parts. For Parts under Warranty, the Serial Number of your machine is required.

PARTS LIST D

KEY NO.	MFG. PART NO.	DESCRIPTION
1D	P10-205-1D	4-0.7X8mm Pan head screw
2D	P10-205-2D	4mm Flat washer
3D	P10-205-3D	Push stick bracket
4D	P10-205-4D	Rear blade guard bracket
5D	P10-205-5D	Front blade guard bracket
6D	P10-205-6D	10mm Flat washer
7D	P10-205-7D	10mm Lock washer
8D	P10-205-8D	10-1.5X25mm Socket head bolt
9D	P10-205-9D	Left base panel
10D	P10-205-10D	Leg
11D	P10-205-11D	Front/rear base panel
12D	P10-205-12D	Right base panel
13D	P10-205-13D	6-1.0mm Hex nut
14D	P10-205-14D	6mm Flat washer
15D	P10-205-15D	Rip fence bracket
16D	P10-205-16D	6-1.0X20mm Socket pan head screw
17D	P10-205-17D	6-1.0X12mm Socket pan head screw
18D	P10-205-18D	Foot
19D	P10-205-19D	8-1.25X16mm Socket pan head screw
20D	P10-205-20D	Front caster support assembly
21D	P10-205-21D	Screw
22D	P10-205-22D	8-1.25mm Lock nut
23D	P10-205-23D	Connecting plate
24D	P10-205-24D	Screw
25D	P10-205-25D	8-1.25mm Lock nut
26D	P10-205-26D	Rear caster support assembly
27D	P10-205-27D	8-1.25mm Lock nut
28D	P10-205-28D	Caster
29D	P10-205-29D	8-1.25X60mm Socket head bolt
30D	P10-205-30D	Push stick
31D	P10-205-31D	Open end wrench
32D	P10-205-32D	4mm Hex wrench
33D	P10-205-33D	5mm Hex wrench
34D	P10-205-34D	6mm Hex wrench
35D	P10-205-35D	8mm Hex wrench

NOTE: Please reference the Manufacturer's Part Number when calling for Replacement Parts.
For Parts under Warranty, the Serial Number of your machine is required.

RIKON

POWER TOOLS®

5-Year Limited Warranty

RIKON Power Tools Inc. ("Seller") warrants to only the original retail consumer/purchaser of our products that each product be free from defects in materials and workmanship for a period of five (5) years from the date the product was purchased at retail. This warranty may not be transferred.

This warranty does not apply to defects due directly or indirectly to misuse, abuse, negligence, accidents, repairs, alterations, lack of maintenance or normal wear and tear. Under no circumstances will Seller be liable for incidental or consequential damages resulting from defective products. All other warranties, expressed or implied, whether of merchantability, fitness for purpose, or otherwise are expressly disclaimed by Seller. This five-year warranty does not cover products used for commercial, industrial or educational purposes. The warranty term for these claims will be limited to a two-year period.

This limited warranty does not apply to accessory items such as blades, drill bits, sanding discs, grinding wheels, belts, guide bearings and other related items.

Seller shall in no event be liable for death, injuries to persons or property, or for incidental, contingent, special, or consequential damages arising from the use of our products.

To take advantage of this warranty, proof of purchase documentation must be provided which has the date of purchase and an explanation of the complaint.

The Seller reserves the right to effect at any time, without prior notice, those alterations to parts, fittings, and accessory equipment which they may deem necessary for any reason whatsoever.

To register your machine online, visit RIKON at www.rikontools.com/warranty

To take advantage of this warranty, or if you have any questions, please contact us at 877-884-5167 or email warranty@rikontools.com



**For more information:
16 Progress Road
Billerica, MA 01821**

**877-884-5167 / 978-528-5380
techsupport@rikontools.com**

